

Gaming, Amusement, Sport Betting, Lottery and Bingo Solutions

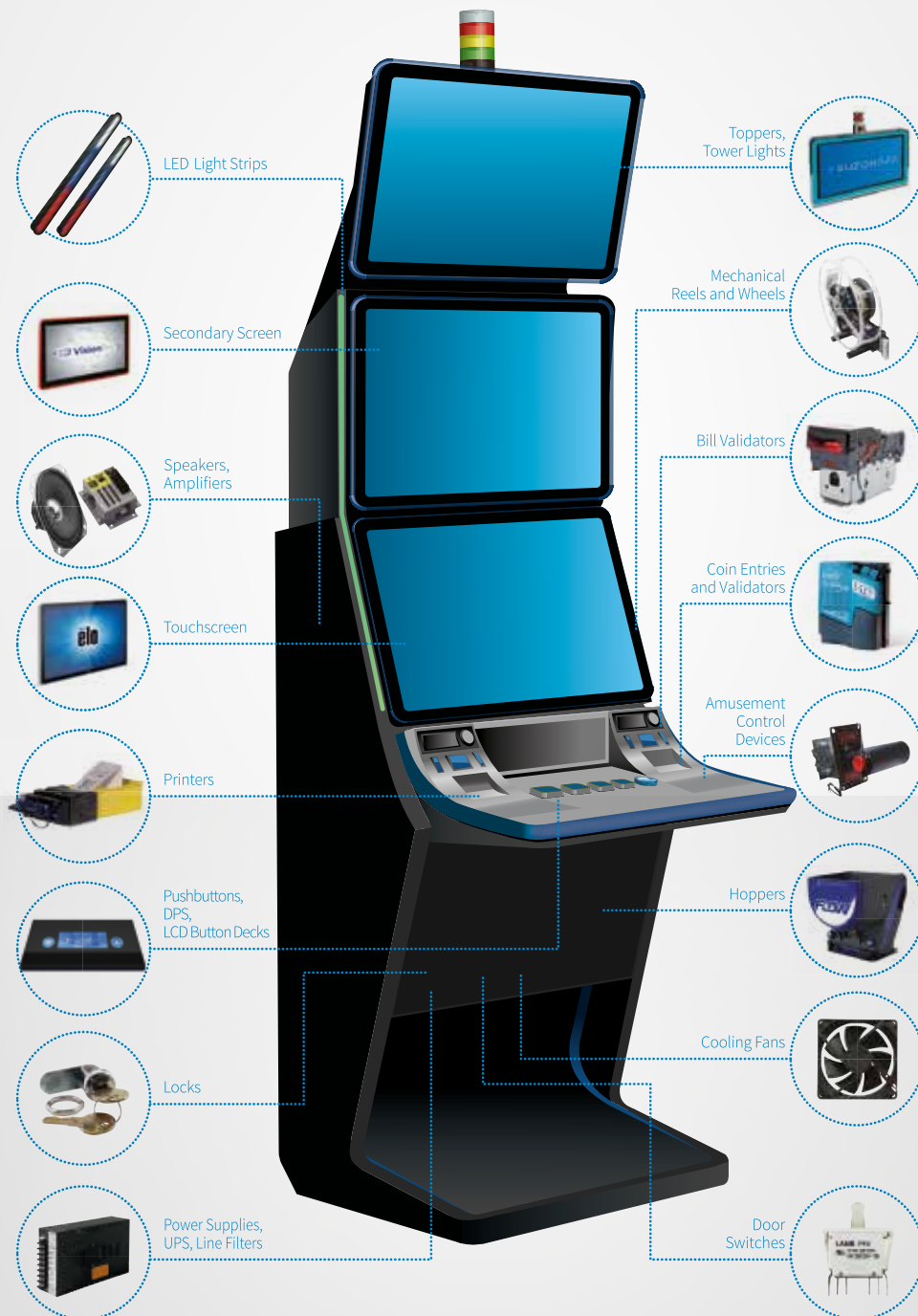



Table of Contents

| | |
|---------------------------------|----|
| About SUZOHAPP..... | 5 |
| Manufacturing Capabilities..... | 7 |
| R&D Capabilities..... | 9 |
| Field Service..... | 11 |

DISPLAYS

| | |
|--|----|
| VisionPro™ LCDs Touch and Non-Touch..... | 14 |
| Edge-Lit LED Monitors..... | 16 |

TOUCH DISPLAYS

| | |
|--|----|
| Elo Touch Solutions Open Frame Monitors..... | 18 |
|--|----|

TOPPERS

| | |
|-------------------------------|----|
| SH 1950 Video Topper..... | 20 |
| Topper..... | 21 |
| Dual Sided LCDs..... | 23 |
| Panels for Slot Machines..... | 24 |

PUSHBUTTONS

| | |
|--|----|
| Dynamic Panel Systems, LCD Pushbuttons..... | 25 |
| Chrome-Luminescent Pushbuttons, STC Pushbuttons..... | 26 |
| RGB Pushbuttons..... | 27 |
| Concave Round Pushbuttons, BL Spinner..... | 27 |
| Square LED Pushbuttons..... | 27 |
| Jumbo Pushbuttons, LCD Button Decks..... | 28 |

COIN VALIDATORS

| | |
|----------------------------|----|
| Coin Entries..... | 29 |
| RM5 HD, RM5 Evolution..... | 30 |
| Coin Sorters..... | 31 |

HOPPERS

| | |
|-------------------------------------|----|
| ICS..... | 32 |
| Cube Hopper, Flow Hopper..... | 33 |
| Evolution Hopper, Excel Hopper..... | 34 |

BILL VALIDATORS

| | |
|----------------------------|----|
| MFL®..... | 35 |
| SC Advance™, Easitrax..... | 36 |
| NV9 USB+, NV10 USB+..... | 37 |
| Bill-to-Bill 300™..... | 38 |

PRINTERS

| | |
|--------------------------------------|----|
| PayCheck® NextGen™..... | 39 |
| PayCheck® 4™..... | 40 |
| PayCheck® Terminal™..... | 41 |
| HSV L Advanced™..... | 42 |
| EZ-Tear™..... | 43 |
| PayCheck® High Speed Couponing™..... | 44 |
| Spill Proof Thermal Printer..... | 45 |
| Spill Proof Cuts Printer..... | 45 |
| Slot Machines Tickets..... | 46 |

CABINET PARTS

| | |
|--|----|
| Barcode Scanners..... | 47 |
| Charge'N Play, Lumia, Protec..... | 48 |
| LED Light Strips & Controllers, Lamps..... | 49 |
| Joysticks, Trackballs, Driving controls..... | 50 |
| Speakers & Amplifiers, Power Supplies..... | 51 |
| Counters, Door Switches, Cooling Fans..... | 52 |
| RGB Handle mechanism, Flip Card unit..... | 53 |
| Custom Reel Mechanisms..... | 54 |
| E-PRL..... | 55 |
| ASSA Desmo Locks..... | 56 |
| VENIA Locks & Keys..... | 57 |
| Xlocks & STC Locks, Security Bars..... | 58 |

CHAIRS

| | |
|-------------------------------|----|
| Zenith, Carrillo, Apollo..... | 59 |
|-------------------------------|----|

REDEMPTION

| | |
|--|----|
| Tickets & Dispensers, Coin Cups & Holders..... | 60 |
|--|----|

ARCADE

| | |
|---------------------------------------|----|
| Air Hockey, Basketballs, Mallets..... | 61 |
|---------------------------------------|----|

POOL CUES, BILLIARD ACCESSORIES

| | |
|--|----|
| Cues..... | 62 |
| Chalk & Tips..... | 64 |
| Accessories..... | 65 |
| Table Lighting, Rules & Scoreboards..... | 68 |
| Refurb Accessories..... | 69 |
| Cloth Cutting..... | 70 |

COIN SORTERS

| | |
|------------------------------|----|
| ICX Active-9..... | 73 |
| DTC series..... | 74 |
| SC-303, SC-350 & SC-360..... | 75 |

BANKNOTE COUNTERS

| | |
|------------------------------|----|
| SC-8220, SC-1600 Series..... | 76 |
|------------------------------|----|

CHANGE MACHINES

| | |
|---|----|
| Swing, Smart Easy..... | 77 |
| Easy PRO, Dual Coin PRO, Jolly PRO, Twin Jolly PRO..... | 78 |

CASHLESS SOLUTION

| | |
|--|----|
| IDEAL Cashless Amusement Solution..... | 79 |
|--|----|

SUZOHAPP

SUZOHAPP is a technology company with over 50,000 gaming, amusement, sport betting, lottery and bingo products for casino operators and gaming OEMs. Products include LCDs, sport betting solutions, toppers, hoppers, locks, coin/bill/reel mechanisms and buttons/decks. SUZOHAPP is also a leading software and hardware supplier of complete cash management solutions typically found anywhere from cashier cages to large-scale back office operations. SUZOHAPP is a global company with offices in 19 countries serving over 25,000 customers with regional delivery, local support and quick customization.



1,100+
employees



50,000+
products



35
facilities



25,000
customers



115
Engineers



Hundreds
of patents



VISION

To be the global market leader in technology-driven cash management, self-service, and gaming devices through our commitment to people, customers, and quality



MISSION

To provide our customers with excellent service and high-quality components, solutions, and software that create significant value for their business



CORE VALUES



AGILITY



CUSTOMER
FOCUS



INNOVATION



INTEGRITY



RELIABILITY



TEAMWORK

PRODUCT BRANDS

SUZOHAPP is a diverse company with multiple brands and product lines

SCAN COIN

Cash**Complete**™

Comestero

BilltoBill™

currenza **C²**

coinco

VisionPro™

CompetitionPro

BilliardPro

InteractivePro

We take pride in our products, we take care of our customers and we value our people

Global Reach

SUZHOP is a global company with a worldwide presence and a diverse workforce. SUZHOP has grown rapidly to meet the needs of the markets, expanding the breadth of its product offering and service capability. Its best-in-class product and service offerings create significant value and operational efficiencies for customers all over the world.

- International coverage through national subsidiaries
- Worldwide presence with a global service network
- Distribution partners all around the globe
- Variety of customers across multiple business segments



Around The World & Around The Corner

In addition to the offices and manufacturing sites located on the map, SUZHOP has strategic partnership agreements with Value Added Distributors, Gaming Channel Partners, and Contract Service providers in those regions where market or license conditions dictate.

Your Strategic Partner

SUZHOP's logistical support and supply chain configuration builds on its total value proposition by providing customers with cost saving delivery "From Our Door to Your Production Floor". Through continuous communication and feedback, the SUZHOP supply chain team works closely with customers and factories to maintain a steady product supply while eliminating costly additional inventory. We are firmly committed to providing the best customer service to all customers.



Manufacturing Capabilities

Adding Value Through Manufacturing

SUZOHAPP continually improves its engineering, manufacturing, service and distribution capabilities to meet the needs and exceed the expectations of its valued customers. With many years of industry experience and production excellence, SUZOHAPP has developed innovative customer-centric engineering and manufacturing processes.

SUZOHAPP designs and manufactures products that are used extensively in Gaming and Amusement devices as well as in demanding Industrial, Vending, and Transportation applications. In-house design, development and production resources located in multiple SUZOHAPP facilities, ensure that projects are efficiently taken from concept to completion.

DESIGN & ENGINEERING



Design & Prototyping

Equipment

- CAD workstations
 - Pro/Engineer
 - SolidWorks
 - AutoCAD
- FDM prototyping machine (3D printing technology)

Capabilities

- Quick turn-around
- In-house prototyping

Resources

- 30 Engineers
 - Electrical
 - Mechanical
 - Software

LCD, TOPPERS & KIOSKS



LCD Production

Equipment

- Integrated toppers
- OEM open frame
- LCD integration
- Signage & custom assemblies
- Bid specification & RFQ

Capabilities

- 20,000 pieces per year

Resources

- 3 Engineers

PLASTIC INJECTION, TOOL & DIE



Direct Injection

Equipment

- 5 - CNC mills
- 5 - Lathes and grinders
- 1 - Wire EDM
- 28 Injection machines

Capabilities

- Sizes from 25-1,600 tons
- 20 million pieces per year
- 24-hour operation
- Insert & over-moulding
- Design to first shoot within 10 days
- 15 tools per month

Resources

- 65 dedicated staff
- +35 flex staff

PCB PRODUCTION



PCB Production

Equipment

- SMT high speed moulder
- SMT inspection
- Wave solder

Capabilities

- Surface mount
- Through-hole
- 150,000 boards per month

Resources

- 25 dedicated staff
- +15 flex staff

ASSEMBLY



Assembly

Equipment

- 12 - Conveyor lines
- 30 - Workstation cells

Capabilities

- 50 assemblies per hour, per line/cell
- Service and Repair
- Assemblies with up to 1,000 components

Resources

- 100 dedicated staff
- +100 flex staff

QUALITY ASSURANCE



Quality

Highlights

- ISO 9001
- Testing services and capabilities

Resources

- 30 FTEs in area of quality control and assurance

Manufacturing and Distribution Facilities



Manufacturing Site China

- Zhuhai, China
- 12,000 sqm
- 250 employees
- Turnkey design / manufacture
- Interactive touch displays
- Transparent LCD technologies
- Cash handling technologies
- Printers, card/barcode readers, NFC/RFID, cameras
- Kiosks, loyalty and betting terminals
- Digital signage
- LED lighting and back lighting technologies



Manufacturing and Distribution Site North America

- Mount Prospect, IL and Las Vegas, NV production locations
- Over 6,000 sqm
- Assembly, Distribution, Service and Support
- Cash Management Solutions: Note recyclers, coin recyclers, deposit safes
- Components & OEM: Joysticks, buttons, coin doors, LCDs, reel mechs, toppers, game controls



Manufacturing Site Poland

- Poznan, Poland
- Over 5,000 sqm
- 60 employees
- Components: Coin validators, coin recyclers
- Solutions: Change machines, cash points for self-service laundrettes, car wash starter systems, cash handling solutions



Assembly and Logistics Hub Netherlands

- Oud-Beijerland, Rotterdam
- 49,000 sqm
- Fully bar-coded warehousing
- Real time data processing systems
- Accurate reporting of inventory
- Excellent customer service

R&D Capabilities

Investment in research and development is a top priority

Global product management teams meet continuously to develop new products and custom solutions for customers' ever-changing needs. Dedicated industrial, mechanical, and electrical engineering teams provide complete design, as well as component selection. SUZOHAPP utilizes contemporary modelling technology to produce accurate designs with competitive costs and short lead times.

Technology Centres

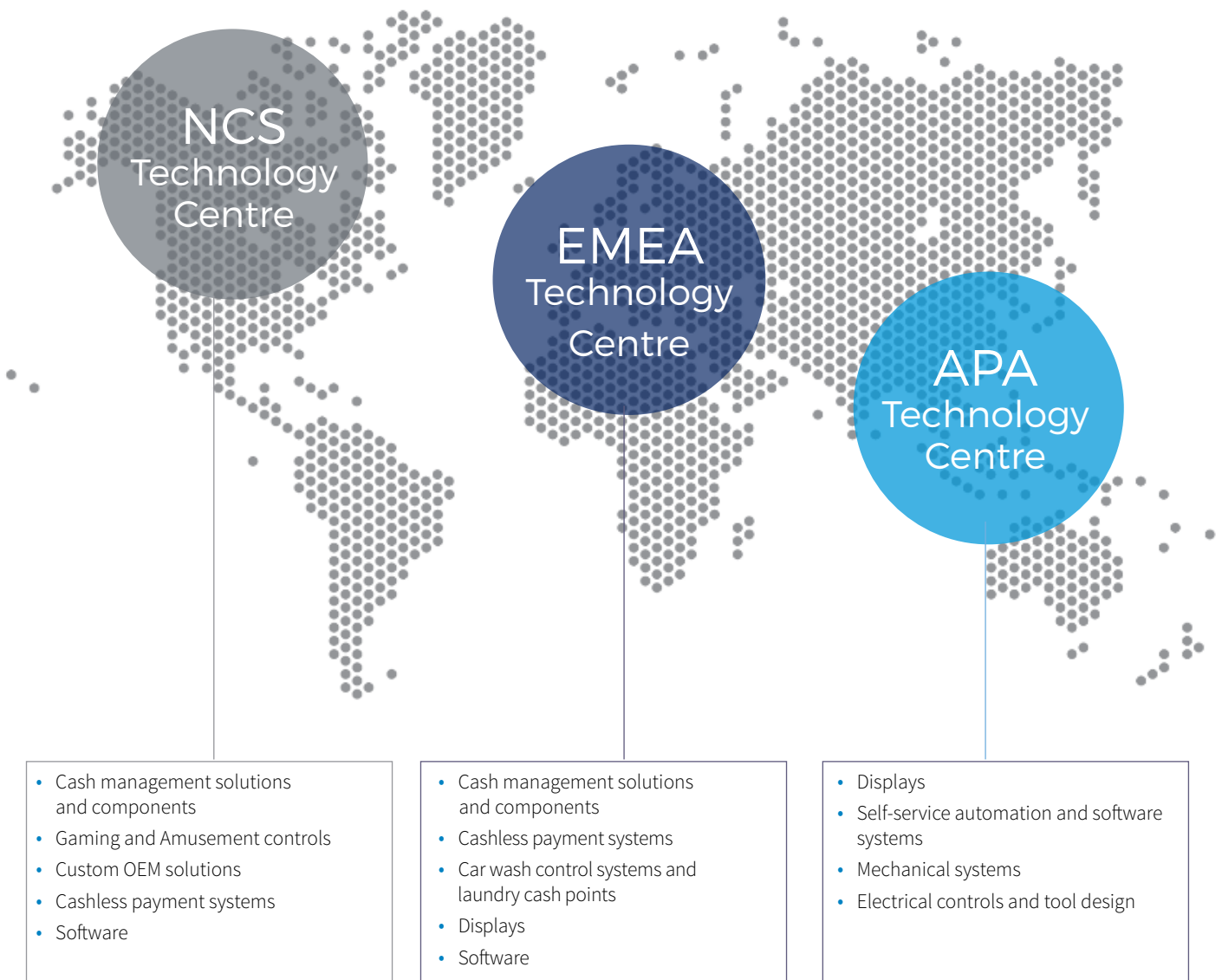

SUZOHAPP's Research & Development team is centralized into one global engineering centre of excellence, SUZOHAPP Technology Services (STS). This highly skilled department develops and supports the company's core technology, accelerates new product development and leads the introduction of innovative technologies.

Design activities and expertise provided include:

- Turnkey design/manufacture of individual parts to complete machines - from concept development through final, highly engineered solutions
- 2D and 3D CAD Design – using SolidWorks for part/assembly modelling and drawings
- Metalwork/plastic design and electrical/wiring harnesses, virtual and physical prototyping, and product renderings
- Design of injection moulds and tooling
- Rapid prototyping through in-house 3D printing capabilities
- Proprietary electronics and PCB Design using the leading software package Altium
- Programming for microprocessors and Advanced Risk Machines (ARM), software development in most operating systems including Windows, Linux and Android OS
- Compliance testing and documentation, including UL

Examples of some of the technologies SUZOHAPP works with:

- The latest LCD and touchscreen technologies, including projective capacitance
- LED lighting and back lighting technologies
- Embedded micro controllers and CPUs
- Electromechanical and mechanical systems

SUZOHAPP's dedicated team has been central to the success of many product deployments to the global amusement, gaming, industrial, transportation and vending markets.

Projects have included:

- LCD retrofit integration
- Custom designed displays, including transparent LCD technology
- Interactive touch displays, large and small
- Cash handling technologies
- Printers, card/barcode readers, NFC/RFID, cameras
- Kiosks, loyalty and betting terminals
- Digital signage



Workshop Service

Highly experienced lab technicians can repair parts to component level, utilizing the latest diagnostic equipment and techniques. SUZOHAPP can also redesign, re-engineer, restore or re-manufacture parts and components reducing your business maintenance costs.

Repair Services

- Electronic gaming machines
- Jackpot systems and player tracking hardware
- POS systems, ATMs, self-service terminals
- Cash handling – bill acceptors, coin mechanisms, hoppers
- Data scanners, PDAs, PC mainboards, logic boards
- LCD displays, touchscreens
- LCD and CRT monitors, power supplies
- Electronic assembly and manufacturing services
- Electronic kiosks
- Wagering terminals
- Other electro-mechanical assembly work

SUZOHAPP technicians are highly skilled

- IPC certified specialist technicians ensure the highest quality in surface mount, hole through and wave soldering
- Experienced in repairing multilayer boards
- Ability to perform circuit programming (FPGA, JTAG) and program microprocessors (TQFP, SSOP, EPROM)

SUZOHAPP technical experts:

- Re-work and re-flow BGA ICs
- Give logic boards, main boards and A-D boards a new lease on life
- Refurbish circuit boards for most popular gaming machines and electronic equipment
- Repair bill validators, ticket printers, hoppers and coin mechanisms, giving considerable savings compared to the cost of replacement

Field Service

SUZOHAPP can provide service contract cover for your equipment or systems, supported by our field service team. Service contract customers have the ability to log calls with our service centre and receive on-site support, with all parts and labour charges covered, for a single annual fee.

No matter if you have a large number of our products, or just one odd note counter to count your daily takings, we can always offer you a suitable type of support.

We offer a range of support options, so let's go through your support needs together. It is possible you have some equipment that is crucial for your business, and therefore might need extra attention than the regular equipment. Our support options can be customised to fit your needs accordingly, which means that you will only pay for what you really need.

We specialize in Coin & Note acceptor reprogramming and Comestero Changer servicing. Perfect for:

- Users that operate equipment on a regular basis and need the equipment up and running
- Users that want an all inclusive support and service package



REPAIR AWARE?

Coin Acceptors
Note Acceptors
Power Supplies
Sega / Namco Game Boards
Scorpion 4 & 5 MPU
LCD Monitors / Touchscreens
Free Collection & Return *

Offer valid for UK customers only

Contact our Sales Team for more info on 0208 391 7700 or sales@suzohapp.co.uk for details

* Minimum 5 items per collection / Average 7 day turnaround / Excludes Northern Ireland / ROI & Certain UK Postcodes, collection / delivery by UPS.

Simplify your sourcing with our broad product

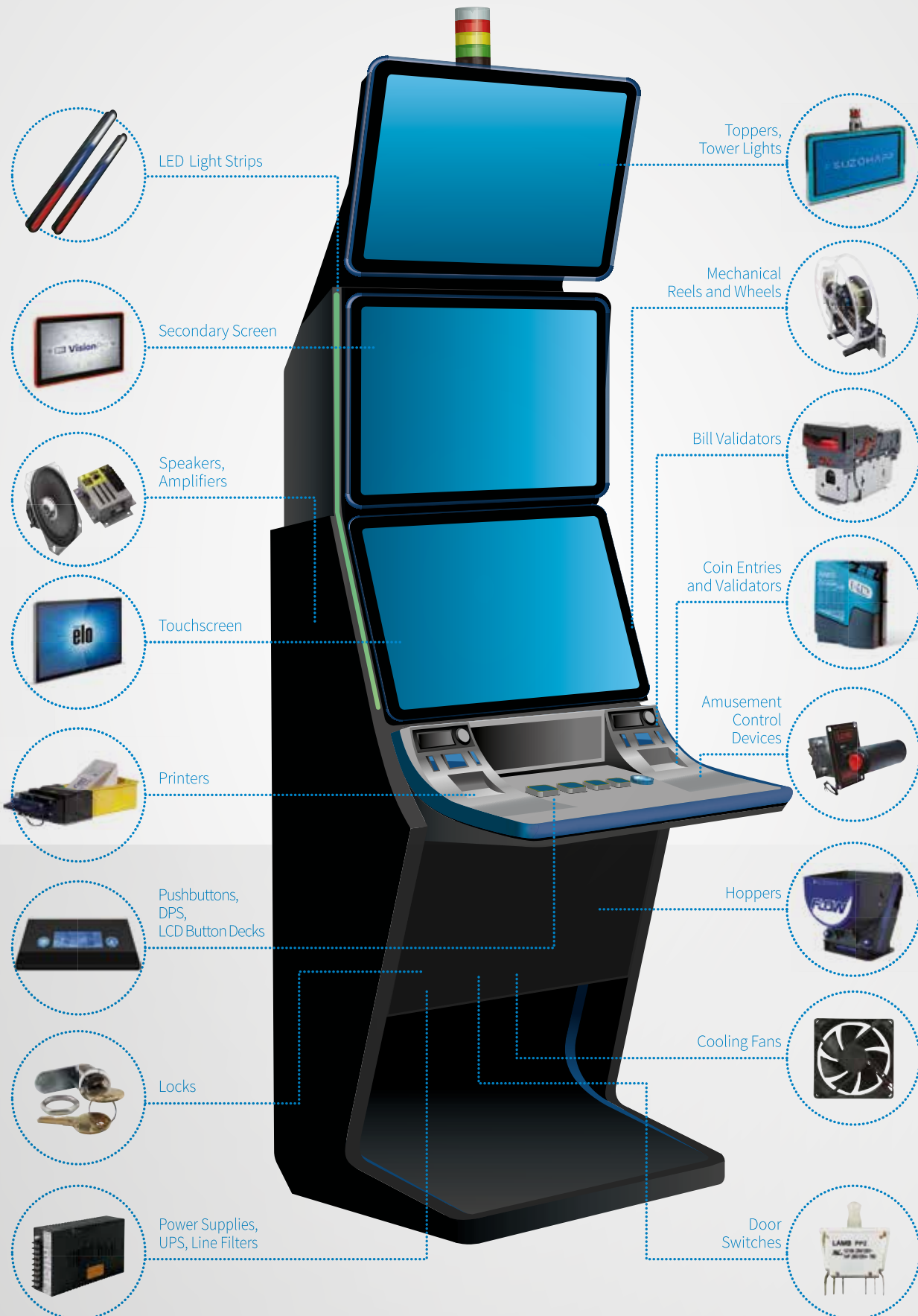

range, local resources and global capability



High Quality LCDs for Gaming, Amusement, Sport Betting, Lottery, and Bingo

Touch and Non-Touch



VisionPro™ is SUZOHAPP's premium line of LCDs using top panel brands and high-quality boards. Fast customization is available for both OEMs and upgrades: 6.2" to 90", specialized panels and integration, customized metal, touchscreens and inputs.

Features:

- ✓ Standard sizes from 15" to 32"
- ✓ Choice of
 - 10+ touch Projected Capacitive (PCAP), true-flat, seamless edge-to-edge glass
 - 3M Surface Capacitive (SCAP) touch technology
 - Protective Glass
- ✓ Standard and wide viewing angle units available
- ✓ Common footprint for touch and non-touch variations
- ✓ DVI and VGA, HDMI and DisplayPort available
- ✓ LED options for surrounding display
- ✓ Economically priced
- ✓ 1-year standard warranty

| Model | Size/Aspect Ratio | Native Resolution | Viewing Angle | Panel Brightness | Contrast Ratio | Touch/Class | Signal Input | Edge-Lit LEDs* | LED Type | Bezel |
|--------------|-------------------|-------------------|---------------|------------------|----------------|--------------------|--------------|----------------|-------------|-------|
| 150TFT2154 | 21.5" 16:9 | FHD | 178 x 178 | 250 | 1000:1 | | VGA/DP | | | |
| 150FTG2154 | 21.5" 16:9 | FHD | 178 x 178 | 250 | 1000:1 | Printed Glass | VGA/DP | | | |
| 150FTFP2154 | 21.5" 16:9 | FHD | 178 x 178 | 250 | 1000:1 | PCAP USB Touch | VGA/DP | | | |
| 150LG2150 | 21.5" 16:9 | FHD | 178 x 178 | 250 | 1000:1 | Printed Glass | VGA/DVI | Integrated | RGB | |
| 150LP2150 | 21.5" 16:9 | FHD | 178 x 178 | 250 | 1000:1 | PCAP USB Touch | VGA/DVI | Integrated | RGB | |
| 150LG2152 | 21.5" 16:9 | FHD | 178 x 178 | 250 | 1000:1 | Printed Glass | VGA/DVI | Integrated | Addressable | |
| 150LP2152 | 21.5" 16:9 | FHD | 178 x 178 | 250 | 1000:1 | PCAP USB Touch | VGA/DVI | Integrated | Addressable | |
| 150DLG2150 | 21.5" 16:9 | FHD | 178 x 178 | 250 | 1000:1 | Printed Glass | VGA/DVI | External | Addressable | |
| 150DLP2150 | 21.5" 16:9 | FHD | 178 x 178 | 250 | 1000:1 | PCAP USB Touch | VGA/DVI | External | Addressable | |
| 150TFT2206 | 22" 16:10 | 1680 x 1050 | 178 x 178 | 250 | 2000:1 | | VGA/DVI | | | |
| 150FTG2206 | 22" 16:10 | 1680 x 1050 | 178 x 178 | 250 | 2000:1 | Clear Glass | VGA/DVI | | | |
| 150FTS2206M | 22" 16:10 | 1680 x 1050 | 178 x 178 | 250 | 2000:1 | 3M Serial Touch | VGA/DVI | | | |
| 150FTS2206MU | 22" 16:10 | 1680 x 1050 | 178 x 178 | 250 | 2000:1 | 3M USB Touch | VGA/DVI | | | |
| 150TFT2302 | 23" 16:9 | FHD | 178 x 178 | 250 | 1000:1 | | VGA/DVI | | | Yes |
| 150FTG2302G | 23" 16:9 | FHD | 178 x 178 | 250 | 1000:1 | Clear Glass | VGA/DVI | | | Yes |
| 150FTS2302MG | 23" 16:9 | FHD | 178 x 178 | 250 | 1000:1 | 3M Serial Touch | VGA/DVI | | | Yes |
| 150FTS2302MU | 23" 16:9 | FHD | 178 x 178 | 250 | 1000:1 | 3M USB Touch | VGA/DVI | | | Yes |
| 150TFT2382 | 23.8" 16:9 | FHD | 178 x 178 | 250 | 1000:1 | | VGA/DP | | | |
| 150FTG2382 | 23.8" 16:9 | FHD | 178 x 178 | 250 | 1000:1 | Printed Glass | VGA/DP | | | |
| 150FTFP2382 | 23.8" 16:9 | FHD | 178 x 178 | 250 | 1000:1 | PCAP USB Touch | VGA/DP | | | |
| 150LG2380 | 23.8" 16:9 | FHD | 178 x 178 | 250 | 1000:1 | Printed Glass | VGA/DVI | Integrated | RGB | |
| 150LP2380 | 23.8" 16:9 | FHD | 178 x 178 | 250 | 1000:1 | PCAP USB Touch | VGA/DVI | Integrated | RGB | |
| 150LG2382 | 23.8" 16:9 | FHD | 178 x 178 | 250 | 1000:1 | Printed Glass | VGA/DVI | Integrated | Addressable | |
| 150LP2382 | 23.8" 16:9 | FHD | 178 x 178 | 250 | 1000:1 | PCAP USB Touch | VGA/DVI | Integrated | Addressable | |
| 150DLG2380 | 23.8" 16:9 | FHD | 178 x 178 | 250 | 1000:1 | Printed Glass | VGA/DVI | External | Addressable | |
| 150DLP2380 | 23.8" 16:9 | FHD | 178 x 178 | 250 | 1000:1 | PCAP USB Touch | VGA/DVI | External | Addressable | |
| 150FTG2414 | 24" 16:10 | 1920x1200 | 178 x 178 | 300 | 1000:1 | Clear Glass | VGA/DVI | | | Yes |
| 150FTS2414M | 24" 16:10 | 1920x1200 | 178 x 178 | 300 | 1000:1 | 3M Serial Touch | VGA/DVI | | | Yes |
| 150FTS2414MU | 24" 16:10 | 1920x1200 | 178 x 178 | 300 | 1000:1 | USB Touch | VGA/DVI | | | Yes |
| 150TFT2705 | 27" 16:9 | FHD | 178 x 178 | 300 | 3000:1 | | VGA/DP | | | |
| 150FTG2705 | 27" 16:9 | FHD | 178 x 178 | 300 | 3000:1 | Printed Glass | VGA/DP | | | |
| 150FTFP2705 | 27" 16:9 | FHD | 178 x 178 | 300 | 3000:1 | PCAP USB Touch | VGA/DP | | | |
| 150FTFP2705S | 27" 16:9 | FHD | 178 x 178 | 300 | 3000:1 | PCAP Serial Touch | VGA/DP | | | |
| 150LG2700 | 27" 16:9 | FHD | 178 x 178 | 300 | 3000:1 | Printed Glass | VGA/DVI | Integrated | RGB | |
| 150LP2700 | 27" 16:9 | FHD | 178 x 178 | 300 | 3000:1 | PCAP USB Touch | VGA/DVI | Integrated | RGB | |
| 150LG2702 | 27" 16:9 | FHD | 178 x 178 | 300 | 3000:1 | Printed Glass | VGA/DVI | Integrated | Addressable | |
| 150LP2702 | 27" 16:9 | FHD | 178 x 178 | 300 | 3000:1 | PCAP USB Touch | VGA/DVI | Integrated | Addressable | |
| 150DLG2700 | 27" 16:9 | FHD | 178 x 178 | 300 | 3000:1 | PCAP Printed Glass | VGA/DVI | External | Addressable | |
| 150DLP2700 | 27" 16:9 | FHD | 178 x 178 | 300 | 3000:1 | PCAP USB Touch | VGA/DVI | External | Addressable | |
| 150TFT3210 | 32" 16:9 | FHD | 178 x 178 | 350 | 3000:1 | | VGA/DVI | | | |
| 150FTG3210 | 32" 16:9 | FHD | 178 x 178 | 350 | 3000:1 | Clear Glass | VGA/DVI | | | |

Notes:

- Specs and drawings, manuals, and CAD files are available upon request.
- The standard models above can be used as a basis for customization. Many other options are available i.e. video inputs including Display Port (DP), DVI, HDMI, customized touchscreens with serial or USB, customized metal, paint and logos, different panels and video resolutions, outdoor and vandal resistance options, and extended warranties.
- Please inquire for other sizes and variations.

Edge-Lit LED Monitors

Gaming Monitors with LED Frames and Halo Effect
Touch and Non-Touch



CHOICES

| | | | |
|----------------------|--|--|-----|
| 1 Size | 21.5" | 23.8" | 27" |
| 2 Design | <ul style="list-style-type: none"> • Integrated for mounting monitor flush inside your cabinet | <ul style="list-style-type: none"> • External for floating monitor outside your cabinet with halo effect | |
| 3 LEDs | <ul style="list-style-type: none"> • RGB solid colour, 12V without IC | <ul style="list-style-type: none"> • Addressable individually driven, 5V with IC | |
| 4 Touch or Non-Touch | <ul style="list-style-type: none"> • 10-touch PCAP | <ul style="list-style-type: none"> • Non-touch 3mm tempered glass | |

FEATURES

- ✓ Rigid high-quality PCB-mounted LEDs, no adhesive strips, no hotspots
- ✓ True-flat design
- ✓ FHD 1920x1080, WVA 178° x 178° for landscape or portrait usage
- ✓ 21.5"/23.8": 250 cd/m², 1000:1
27": 300 cd/m², 3000:1
- ✓ 10-touch PCAP for Windows 7 or later, Linux 4.4 or later
- ✓ VGA + DVI standard, HDMI and DisplayPort available
- ✓ 12V DC or 100-240V AC (brick optional)
- ✓ Operating temperature: 0-50 °C
- ✓ CE, RoHS
- ✓ Drawings and CAD files available on request
- ✓ Customization possible

2 Design



Integrated Design

For mounting monitor flush inside your cabinet. Accent your display with a frame of colour.



External Design

For floating monitor outside your cabinet. Surround colour in front, side, rear for a halo effect.



| 1 Size | 2 Design | 3 LEDs | 4 Touch or Non-Touch | Max Dimensions (WxHxD) | Part Number |
|-----------|-------------|-------------|-------------------------|---|-------------|
| 21.5" | Integrated | RGB | PCAP 10-touch | 21.3" x 13.3" x 2" (541.8 x 336.4 x 51.0 mm) | 150LP2150 |
| | | | 3mm tempered glass | | 150LG2150 |
| | | Addressable | PCAP 10-touch | | 150LP2152 |
| | | | 3mm tempered glass | | 150LG2152 |
| | External | Addressable | PCAP 10-touch | 22.1" x 14.1" x 2.2" (562.6 x 357.2 x 56.0 mm) | 150DLP2150 |
| | | | 3mm tempered glass | | 150DLG2150 |
| 23.8" | Integrated | RGB | PCAP 10-touch | 23.1" x 14.4" x 2" (587.8 x 366.8 x 51.0 mm) | 150LP2380 |
| | | | 3mm tempered glass | | 150LG2380 |
| | | Addressable | PCAP 10-touch | | 150LP2382 |
| | | | 3mm tempered glass | | 150LG2382 |
| | External | Addressable | PCAP 10-touch | 24" x 15.3" x 2.2" (608.6 x 387.6 x 56.0 mm) | 150DLP2380 |
| | | | 3mm tempered glass | | 150DLG2380 |
| 27" | Integrated | RGB | PCAP 10-touch | 26" x 16" x 2" (659.8 x 406.8 x 51.0 mm) | 150LP2700 |
| | | | 3mm tempered glass | | 150LG2700 |
| | | Addressable | PCAP 10-touch | | 150LP2702 |
| | | | 3mm tempered glass | | 150LG2702 |
| | External | Addressable | PCAP 10-touch | 26.8" x 16.8" x 2.2" (680.6 x 427.6 x 56.0 mm) | 150DLP2700 |
| | | | 3mm tempered glass | | 150DLG2700 |

Elo Touch Solutions Open Frame Gaming Monitors



Brilliant Display. Superior Quality. Competitive Price.

Engineered and designed specifically for the demanding requirements of the gaming industry, the 90-Series open-frame displays feature touch technology that is built-in rather than glued-on. Elo is the world leader in commercial touch with over 20 million installations, half a million units per years, nearly 2,000 units per day.

Select from a wide range of sizes from 10" to 27" to fit in any gaming environment. Other Elo products extend the range to 70".

Only Elo produces the touchscreens, controllers, drivers, and monitor for a complete solution proven in 10,000s of gaming installations.

Take advantage of these great features:

- ✓ Next generation Projected Capacitive (PCAP) 2GS technology (2 glass solution)
- ✓ Highest optical quality and longevity as no plastic films, no metal mesh
- ✓ 10-touch true-flat solution
- ✓ Thru-glass mode which operates through up to 6 mm customer-supplied glass
- ✓ Common mechanical and electrical components across the line for easy design-in, compliance testing, service, and transition between sizes
- ✓ HDMI, DisplayPort, VGA inputs, with common port design across all units
- ✓ Built-in watertight edge seal
- ✓ Magnetic tethered OSD control box
- ✓ Unique field-replaceable touchscreen glass design
- ✓ Global agency approvals: United States UL, FCC; Europe CE TÜV; Australia RCM; Canada cUL, IC; China CCC; Japan VCCI; Korea KCC; Mexico CoC; Taiwan BSMI; International CB; RoHS
- ✓ Passes UL and IK07 Ball Drop tests
- ✓ 50,000 hour demonstrated MTBF
- ✓ 3-year standard global warranty



New sleek finished enclosure

| Model | Diagonal size | Aspect ratio | Contrast ratio | Brightness (panel) | Viewing angle | Native resolution |
|-------|---------------|--------------|----------------|--------------------|---------------------------|-------------------------|
| 1093L | 10.1" | 16:10 | 800:1 | 350 nits | 85°/85° or 170°/170° | 1280 x 800 at 60Hz |
| 1291L | 12.1" | 4:3 | 1500:1 | 450 nits | 89°/89° or 178°/178° | 800 X 600 at 60Hz |
| 1590L | 15" | 4:3 | 800:1 | 300 nits | 80°/70°- 80° or 160°/150° | 1024 X 768 at 60Hz |
| 1593L | 15.6" | 16:9 | 500:1 | 300 nits | 80°/80° or 160°/160° | 1366 x 768 at 60Hz |
| 1790L | 17" | 5:4 | 1000:1 | 250 nits | 85°/80° or 170°/160° | 1280 x 1024 at 60Hz |
| 1990L | 19" | 5:4 | 1000:1 | 250 nits | 85°/80° or 170°/160° | 1280 x 1024 at 60Hz |
| 1991L | 19" | 5:4 | 1000:1 | 250 nits | 89°/89° or 178°/178° | 1280 x 1024 at 60Hz |
| 2094L | 19.5" | 16:9 | 3000:1 | 250 nits | 89°/89° or 178°/178° | 1920 x 1080 at 50, 60Hz |
| 2293L | 21.5" | 16:9 | 1000:1 | 250 nits | 85°/80° or 170°/160° | 1920 x 1080 at 50, 60Hz |
| 2294L | 21.5" | 16:9 | 1000:1 | 250 nits | 89°/89° or 178°/178 | 1920 x 1080 at 50, 60Hz |
| 2494L | 23.8" | 16:9 | 3000:1 | 250 nits | 89°/89° or 178°/178 | 1920 x 1080 at 50, 60Hz |
| 2794L | 27" | 16:9 | 3000:1 | 300 nits | 89°/89° or 178°/178 | 1920 x 1080 at 50, 60Hz |

10" to 27" desktop touchmonitors, All-in-Ones and interactive digital signage from 10" to 70"

SUZOHAPP also distributes the complete line of Elo Touch Solution products — seen in cashier cages, sports betting outlets, and on the gaming floors in top casinos around the world. Monitors and All-in-Ones for front/back office, interactive digital signage, bingo, lottery, sport betting, player tracking, loyalty systems and POS.



SH1950 Video Topper

19.5" high viewing angle panel with LED back light

The SH1950 Video Topper consists of a 19.5" wide viewing angle panel with LED back light, VGA or DVI cable out, 12V input and can be equipped with a black or chrome bezel. The sides have RGB illumination covered by an acrylic front plate. The SH1950 Video Topper and Edge Lit Topper are manufactured in SUZOHAPP China, in accordance to the highest standards. Final assembly, as well as customizations are done at a regional production facility.

The SH1950 Video Topper is a great addition to every cabinet!



19.5" high viewing angle panel with LED back light (optional without LCD to be used as a light box)

RGB Mini Topper



- ✓ Whole unit operates on a safe 12Vdc
- ✓ Different attract modes in a program such as twinkling, full on, rotating left to right and right to left, filling rotation etc
- ✓ Standard supplied with 32 bright white LEDs (7 different light brightness selections on the topper control board)
- ✓ Standard supplied with bright chrome bezel
- ✓ Mounting location and through holes for tower lights in the top of the body
- ✓ Flat, angled or radius base options for different cabinet configurations, easy mounting with two threaded studs
- ✓ Metal mounting bracket available for mounting on existing tower light fitting holes, to be used in conjunction with mounting bracket

RGB Polygon Topper



- ✓ Completely backlit thanks to bright white LEDs
- ✓ Includes tower light with colour foils
- ✓ On board PCB allows stand-alone operation or synchronization of up to eight topper boxes
- ✓ Seven pre-programmed flashing patterns
- ✓ Different attract modes including full on, rotating left to right and right to left, flashing and more
- ✓ Optional mounting base available
- ✓ Artwork not included

RGB Tower Light Topper



- ✓ Designed to be mounted on top of any standard round classic tower light
- ✓ Great for advertising special machine features such as Multi-Denomination, Ticket-In Ticket-Out, Hot New Game, Server Based Gaming, etc.
- ✓ Translucent bezel with 20 ultra-bright Nichia multi-colour
- ✓ RGB LED's provide light output for an elegant multi-coloured lightshow
- ✓ Pre-programmed with 8 unique flashing patterns and 7 different colour combinations
- ✓ Several optional base/cap adapters make it easy to use on other styles of tower lights

RGB Ellipse Topper



- ✓ On board PCB allows stand alone operation or synchronisation of up to 8 topper boxes
- ✓ Toppers can be synchronised to create unique patterns, for example a snake pattern that runs from one topper to the next
- ✓ 7 pre-programmed flashing patterns
- ✓ Different attract modes including twinkling, full on, rotating left to right and right to left, flashing and more
- ✓ Ultra bright LEDs guarantee unequalled light output for a spectacular multicoloured lightshow
- ✓ Backlit by 11Watt SL Lamp
- ✓ Translucent bezel contains 40 ultra bright nichia RGB LEDs for a multi-coloured light show
- ✓ Whole unit operates on 12VDC power
- ✓ Optional flat or radius mounting brackets with two mounting studs available to accommodate different cabinet configurations
- ✓ Body is constructed of black LL-94 VO ABS flame resistant plastic, color customisation available
- ✓ Tower Light and artwork panel not included

RGB Topper Accessories



95-2862-00
Topper Base for
RGB Toppers, Flat



95-2863-00
Topper Base for
RGB Toppers, Round



95-2864-00
Topper Base for
RGB Toppers, Arch



95-2865-00
Topper Base for
RGB Toppers, Slant

RGB Mini Topper



- ✓ Low profile to accommodate locations where ceiling height is a problem
- ✓ On board PCB allows stand alone operation or up to 8 toppers to be synchronized to work in a collective pattern
- ✓ Toppers can be synchronised using cables to create unique patterns, for example, a snake pattern that runs from one topper to the next
- ✓ Made of durable flame resistant UL-94 VO ABS plastics with chrome bezel
- ✓ Back lit by 11Watt SL Lamp
- ✓ Ultra bright LEDs guarantee unequalled light output for a spectacular lightshow
- ✓ Chrome bezel contains 32 bright LEDs
- ✓ 7 pre-programmed flashing patterns
- ✓ Different attract modes including twinkling, waves, fades and rollercoaster effects
- ✓ Whole unit operates on 12VDC power
- ✓ Optional mounting base (104-0025) and blank plexi panel (96-091500)
- ✓ Tower Light and artwork panel not included



95-2846-00

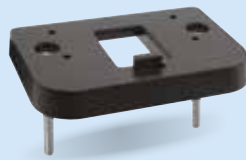

104-0025

LED Topper Accessories



Topper Mounting Base, Flat
104-0020-1



Compact Fluorescent Lamp
9902-11



Topper Box Synchroniser
104-0051

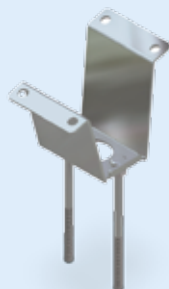

Tower Light Adapter Bracket
104-0001

Upright Topper



Round Topper



Round Video Topper



RGB LED Light Strips

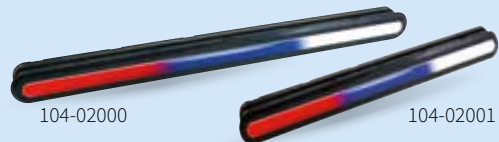

RGB LED Light Strip – 10 and 20 LEDs

- ✓ Light strips with opaque bezel contains bright multi colour LEDs and when mounted to your cabinet they provide a dazzling light show
- ✓ When used with RGB Xenon Topper it runs from the topper box into the light strips and back
- ✓ Light strip controllers provide 7 pre-defined colours and 7 pre-defined flashing patterns
- ✓ +12vdc Operation
- ✓ LED Light Strip Controller sold separately
- ✓ Wire harness sold separately



104-0062

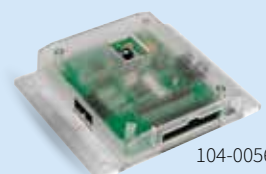

104-0056

Light Strip Controller – 20 and 40 LEDs

Dual-Sided LCDs Interior Signage

Perfect for casinos, table games, signage or other interior environments

With its stylish design the Dual-Sided LCDs displays are a slick way to share content, catching customers coming and going. Available in three distinct sizes to insure the perfect fit for your venue. The low power requirements allow the display to stand out just about anywhere. To eliminate dual graphic and multiple PC issues both displays are driven by a single HDMI signal source.

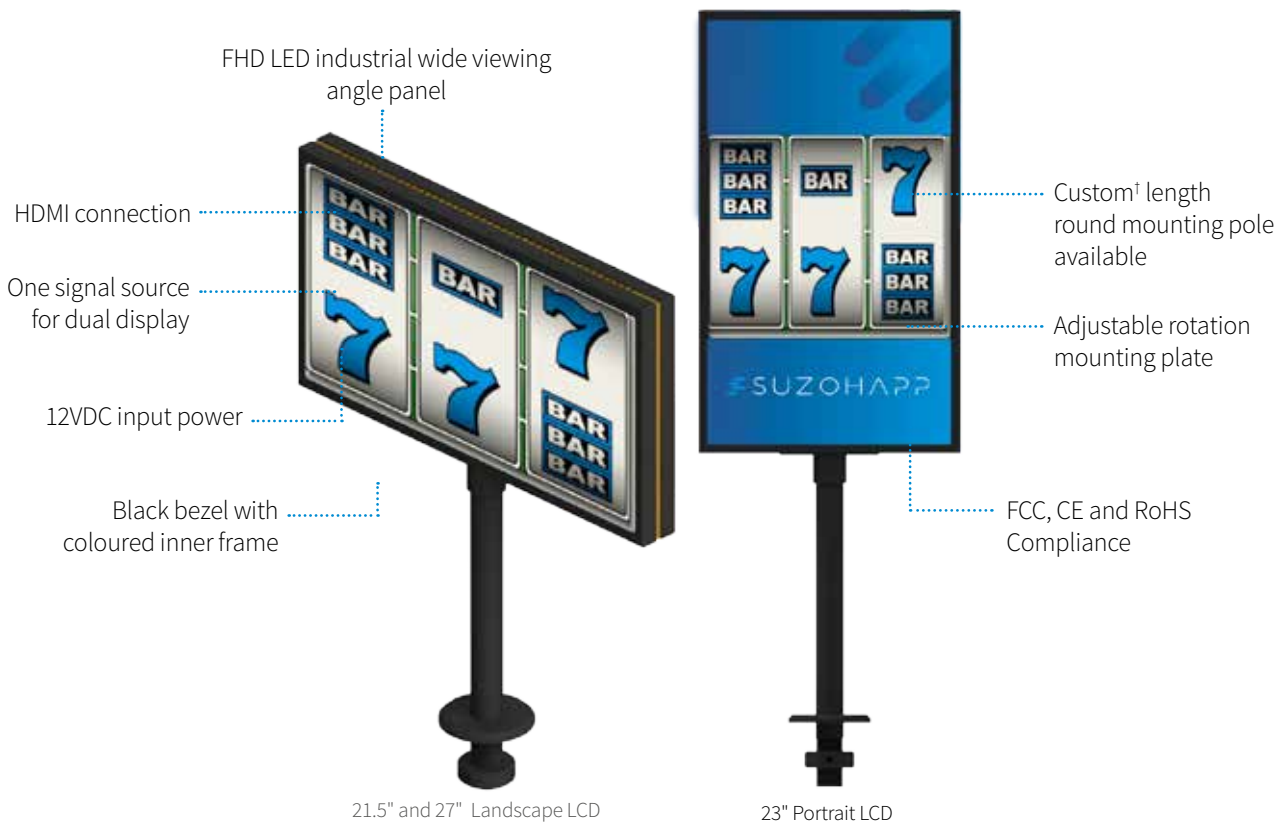

1 M[†] round pole with black bezel with added gold* edge featured

*Different outer and inner colour available upon request but MOQ's apply.
[†] Custom pole length and base mounting options available upon request but MOQ's apply.

Technical Specifications

| Screen Diagonal | 21.5" | 23" | 27" |
|-----------------------|-----------------------|-----------------------|-----------------------|
| Orientation | Landscape | Portrait | Landscape |
| Resolution | FHD 1920 x 1080 | FHD 1920 x 1080 | FHD 1920 x 1080 |
| Panel Brightness | 250 cd/m ² | 250 cd/m ² | 250 cd/m ² |
| Contrast Ratio | 3000:1 | 1000:1 | 1000:1 |
| Operating Temperature | 0 ÷ 50 °C | 0 ÷ 50 °C | 0 ÷ 50 °C |
| Viewing Angle | 89° all sides | 89° all sides | 89° all sides |
| Power Requirements | 12vDC | 12vDC | 12vDC |
| Display Height | Custom [†] | Custom [†] | Custom [†] |

Panels For Slot Machines



Superior lighting technology now used in Gaming and Amusement Industry!

CUSTOM SIZES AVAILABLE

- ▶ No hot or cold spots
- ▶ Illuminates from the sides of the frame and creates a smooth full light without bright spots and shadows that occur with traditional back-lit panels
- ▶ Restore your older machines with a new, modern look
- ▶ Each model is engineered specifically for the exact application
- ▶ Low heat generation saves life of entire machine while significantly lowering air conditioning costs to casino floor
- ▶ Light PRO LED panels offer energy savings from 60-80%
- ▶ No mercury contamination to the planet and low carbon footprint
- ▶ Green energy efficient LED technology
- ▶ Available in three shades of white: Warm White, 3500K; Cool White, 5100K; Daylight, 6000K
- ▶ 5 year typical lifespan

Dynamic Panel Systems

SUZOHAPP's Dynamic Panel Systems (DPS) feature the latest innovation in pushbuttons - all the adaptability of touchscreens with the tactile satisfaction of mechanical pushbuttons. We remove the limits of standard LCD pushbuttons in both shape and content, utilizing a single LCD with a unique fibre optic conduit to elevate the image to the surface of the injection moulded plastic lens cap. Easily program the entire deck at once with dynamic and configurable content allowing for unprecedented interaction between games and buttons as well as ease of transition between content.

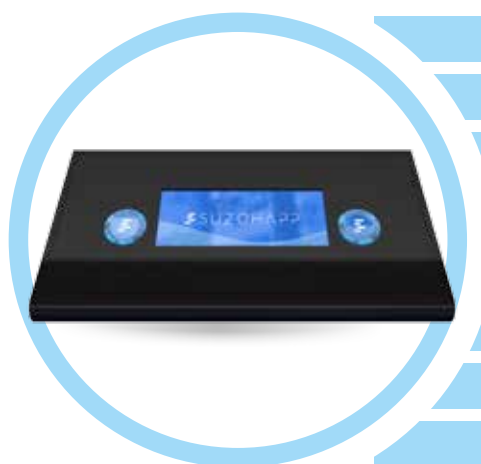

Self-labeling buttons without the complexity or cost

Touchscreen flexibility, with familiar tactile feel

Optional illuminated RGB bezel

Confidence and speed of a physical button

Excellent visibility without glare or distortion

Interfaces: VGA, DVI-D or LVDS

Button interface is available in RS232 or USB

DisplayPort and HDMI are available upon request

Advantages

- ✓ Incredibly flexible – the display panel and buttons can be virtually any size to fit your cabinet and the buttons can be manufactured in any shape
- ✓ Innovative use of precision image transfer fibre optics
- ✓ Traditional tactile pushbutton feel
- ✓ Display graphics, text, animations, video, and even highlight error states with moving colour
- ✓ Add versatility and intrigue to games to attract attention

LCD Pushbuttons

The LCD Button unit is an innovative addition to the SUZOHAPP range for gaming devices, giving the game designer the additional tools to enhance the content and player of new gaming machine concepts.



LCD is integrated into the button and moves with lens cap

Light ring comes in a range of colours

Option to customize LCD decal surround (black standard)

24 frames per second animation

Full colour 128 x 128 pixels

USB interface, controller board controls up to 16 buttons

Chrome-Luminescent Pushbuttons

Polished chrome-plated button bezel with translucent colour washer moulded in bezel to provide edge luminescent effect. Available in several colour combinations of button & luminescent effect. Additional customization also available.

- ▶ Locking nut has special design to allow it to fit over “Snap-Tab” feature with microswitch installed
- ▶ Ease & flexibility of mounting to metal control panels using either the “Snap-Tab” or traditional locking nut
- ▶ Switch pre-assembled on button for reduced assembly time into control panel
- ▶ Subminiature microswitch provides additional clearance room under control panel
- ▶ Polycarbonate lens for optical clarity and durability
- ▶ Switch snaps on bezel of button eliminating the need to have separate lamp holder
- ▶ Grounded for ESD protection



Design Your Casino Chrome-Luminescent Pushbutton with the Matrix Below

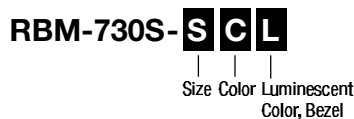

| S = Size | C = Lens Colour | L = Luminescent Effect |
|---------------------|--------------------|------------------------|
| A = Large Square | 2 = Red | 2 = Red |
| B = Small Square | 3 = Amber (Orange) | 3 = Amber (Orange) |
| C = Large Rectangle | 4 = Yellow | 4 = Yellow |
| D = Small Rectangle | 5 = Green | 5 = Green |
| E = Large Round | 6 = Blue | 6 = Blue |
| F = Small Round | 9 = White | 9 = White |

Nut Sold Separately, Part number RBM-K730-001

STC Pushbuttons

STC Pushbuttons with Subminiature Microswitch designed to retrofit all existing VLT/Poker buttons which use a 22 mm square mounting hole. Available in 6 different colours: red, orange, yellow, green, blue or white.

- ▶ Designed to resist spills and sticking, for high reliability and long life, tested for 10 million+ cycles
- ▶ Standard supplied with spacer bezel for mounting on top or in the panel (low-profile)
- ▶ Small size, low profile, provides maximum player comfort
- ▶ Full 0.5 mm thickness on lamp terminals holds lamp or led connectors securely
- ▶ For use with 5 mm wedge base lamps or leds (not included)
- ▶ Standard fitted with Cherry DB5 style microswitch with 2.8 mm terminals for easy connection



RGB Illuminated Pushbuttons

Features

- ▶ 13 different display modes
- ▶ Top quality with a competitive price
- ▶ Magnificent lighting effects
- ▶ Simple installation
- ▶ Available in different colours



RGB Controllable Pushbuttons

Features

- ▶ Built-in RGB LED PCB - it can be controlled by LED driver with constant current output
- ▶ Built-in microswitch
- ▶ Made with highest quality raw materials
- ▶ Suitable to be used for various machines
- ▶ Over 10 million times reliability test for microswitch with gilded contact legs
- ▶ Connection options: 6pin connector, 110" terminal



Concave Round Pushbuttons



Features

- ▶ Special anti-scratch material - with stunning flashing vehicle baking finish appearance
- ▶ Built-in microswitch
- ▶ Top quality with a competitive price
- ▶ Suitable to be used for various machines

BL Spinner



Features

- ▶ Whole metal structure - High durability
- ▶ Moisture-proof plastic cover design
- ▶ Built-in automatic RGB LED lighting effect
- ▶ Made with highest quality raw materials
- ▶ Suitable to be used for various machines

Square LED Pushbuttons

Features

- ▶ Two colour design - Unique and very attractive appearance
- ▶ Built-in lighting LED design with 110 terminals
- ▶ Built-in microswitch
- ▶ Suitable to be used for various machines
- ▶ Over 10 million times reliability test for microswitch with gilded contact legs



Jumbo Pushbuttons

Features

- ✓ Achieves magnificent lighting effects
- ✓ 13 different display modes to control.
Enhance user interaction for your machine
- ✓ Top quality with a competitive price
- ✓ Simple installation takes your machine assembly to the next level
- ✓ Available in different colours



Jumbo IPB White
Black Trim - RGB LED UFO Style



Jumbo Circular Button White Legend Colour Lens

| | |
|---------------------|----------------------|
| 75-4002-10187 Red | 75-4002-13187 Green |
| 75-4002-11187 White | 75-4002-15187 Yellow |
| 75-4002-12187 Blue | 75-4002-17187 Orange |

LCD Button Decks

15" 1/3 LCD Button Deck

- ✓ 10-point PCAP
- ✓ 170°/160° viewing angle
- ✓ 2T glass
- ✓ Black masking
- ✓ R5 corners
- ✓ USB



16.4" LCD Button Deck

- ✓ 170°/160° viewing angle
- ✓ 10-point PCAP
- ✓ 2T glass
- ✓ Black masking
- ✓ USB



16.4" LCD Button Deck with customized glass

- ✓ 170°/160° viewing angle
- ✓ 10-point PCAP
- ✓ 2T glass
- ✓ Black masking
- ✓ USB
- ✓ 1 push button hole

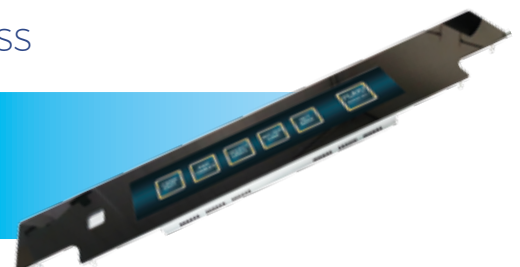

Coin Entries

For application on flat surfaces and with various inclinations

Devices in different colours and sizes. Some models are equipped with lighting to attract more attention.



Standard coin entry for flat surfaces. Available in chrome or gold finish, with coin reject lever



Adjoining coin entry flat surfaces. Available in chrome or gold, with coin reject lever



Coin entry for flat surfaces. Available in black ABS, with coin reject button, in the lengths of 7-20-30 and 45 mm



Top coin entry for flat surfaces. Available in chrome plated steel, with coin reject button



Coin entry for surfaces with a 30° inclination. Available in chrome or gold finish, with coin



Coin entry for surfaces with a 30° inclination. Available in black, chrome or gold finish, with a coin reject button and in lengths of 42.5 – 62.8 mm



Coin entry for surfaces with a 30° inclination. Made of die-cast material with a coin reject button and in lengths of 42.5 – 62.8 mm



Standard coin entry for inclined surfaces. Solid and robust, it is made of chrome plated steel, with coin reject button. It accepts coins up to 3 mm thick



Cast metal coin entry for surfaces with a 15° inclination. Characterized by its sharp lines and catchy design



Coin entry for surfaces with a 30° inclination. It is available in chrome plated steel, with a coin reject button and luminous "COIN" inscription

RM5 HD

Extreme reliability, remarkable acceptance speed and high versatility

The RM5 HD coin validator has set new reference standards in coin validation. Through 5 different sensors and 10 recognition parameters, it ensures a high level of recognition and discrimination of valid and counterfeit coins with an unprecedented speed of up to 6 coins per second.



HD high-discrimination system based on 10 different parameters regarding frequency, dimensions and phase

5-sensor identification technology: 3 inductive sensors, 1 optical sensor and 1 magnetic sensor

USB version also available

Advanced electronic and mechanical anti-fraud system: electronic anti-fishing device, coin movement direction detection, 3 mechanical traps, and wire cutting blade

Tropicalised version also available for environments affected by adverse weather conditions

over 2 million Comestero coin mechanisms installed!

RM5 Evolution

The record-breaking coin validator

The RM5 Evolution coin validator is well known for its quality and reliability. Its electronics combines extraordinary selectivity with extreme programming versatility: the Cloning system allows the transfer of the configuration parameters.



3 pairs of inductive sensors for processing 6 different parameters regarding the material and the mass

3 pairs of optical sensors for determining the coin's diameter

Identification channels: up to 59, each of which can be redirected to the outlets. The first 6 support Self-Prog mode

A mechanical and electronic anti-fishing device

Serial interface for external connections (portable programmer or PC)

Credit recognition: parallel, binary, pulse

Coin Sorters

CINCO

Coin sorter with 5 sorting paths plus reject mechanism specifically designed to satisfy the requirements of any type of gaming machine. It can be installed both on machines operating in ccTalk and in parallel, allowing switching modes with ease.



SPS41LCC4

Coin sorter with 4 in-line sorting paths and reject placed over the third sorting outlet.

SPS31LCC3

Coin sorter with 3 in-line sorting paths and reject placed over the third sorting outlet.



SPS31SCC3

Coin sorter with 3 in-line sorting paths and reject placed over the last sorting outlet.

SPS300CC3/VER-B

Coin sorter with 3 in-line sorting paths and a bottom reject mechanism.



SPS300CC3

Coin sorter with 3 in-line sorting ways and front reject.

ICS (Intelligent Coin System)

The innovative coin handling device

The ICS is a revolutionary coin handling device able to process up to 8 different size coins without the need of pre-sorting the coins by the user. Due to its compact design and spacious size (up to 1,300 various sized coins), it is ideal for many applications, and supports a minimum coin-in to coin-out height solution. Thanks to its patented design and SUZOHAPP's long-standing experience in coin handling, this device is the world's first currency solution able to be integrated into machines from diverse markets including parking ticket machines, self-checkout stations, money changers, kiosks and vending. ICS's intelligent interface gives you the possibility to directly manage the pay-out composition or make the calculation itself as to the amount of coins per type to be supplied based on the denomination it holds. It is also able to dispense 4 coins simultaneously.



* value can change according to currency

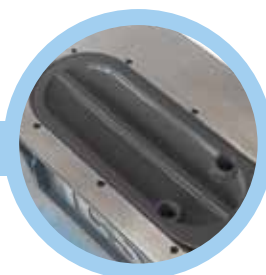

Compact design:
one product that works as 8 hoppers + 1 sorter



High pay-out speed and safety:
it guarantees the correct pay-out per coins' denominations

Cube Hopper

High speed single denomination hopper

The Cube Hopper has an expandable hopper capacity and is made from extremely strong, wear-resistant plastics. With one configuration it covers different coin sizes, and in case of conversion the disc can be replaced in seconds to convert the denomination of the hopper. The hopper is square and easy to mount by means of standard mounting bracket. By using a unique “Sun & Planet” gearbox system, this hopper offers the possibility to contain and count (with two extensions) over 1,200 coins of ø 24 mm. The hopper is protected by an auto-reverse anti-jam system and has an indirect optical readout with a continuous monitored optic sensor control. A low-level detection is integrated in the coin cup. A Dual Hopper version is also available which can pay-out two different types of coins.



Flow Hopper

Innovative through-hole hopper

The innovative electronics and high-resistance plastic materials ensure durability over time. Available in two interfaces – standard parallel and ccTalk serial. Supplied with quick-release plate.



3 DIFFERENT COIN BOWL SIZES



Medium cup

Intermediate cup

Large cup

Evolution Hopper

High dispensing speed and reliability come together

Based on a belt drive, Evolution Hopper is excellent in terms of both performance and ease of maintenance. The unique concept provides a single build type hopper that is suitable for 95% of the world's coins and tokens without needing adjustments. A large DC motor in combination with an electronic motor control board yields reduced friction and motor noise. The optic board is easily accessible by removing the electronic control board from outside the hopper.

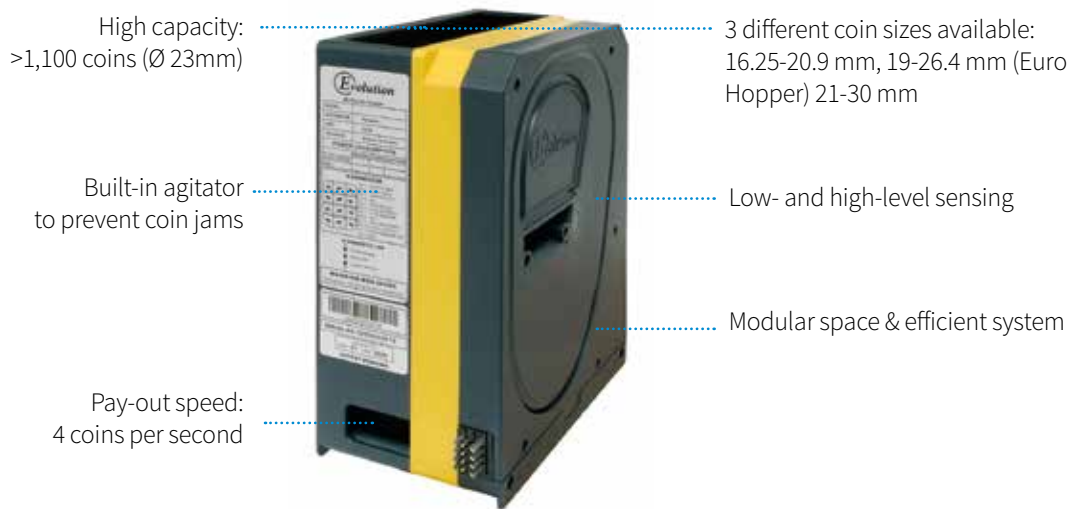

Excel Hopper

Extremely durable and the most service-friendly casino hopper

Its gearbox system design provides advantages such as maximum torque with minimum power consumption, unique bayonet motor connection for easy motor replacement, and an easily-accessible coin exit. Available with 3 different bowls: standard bowl, wide or narrow bowl and extended bowl.

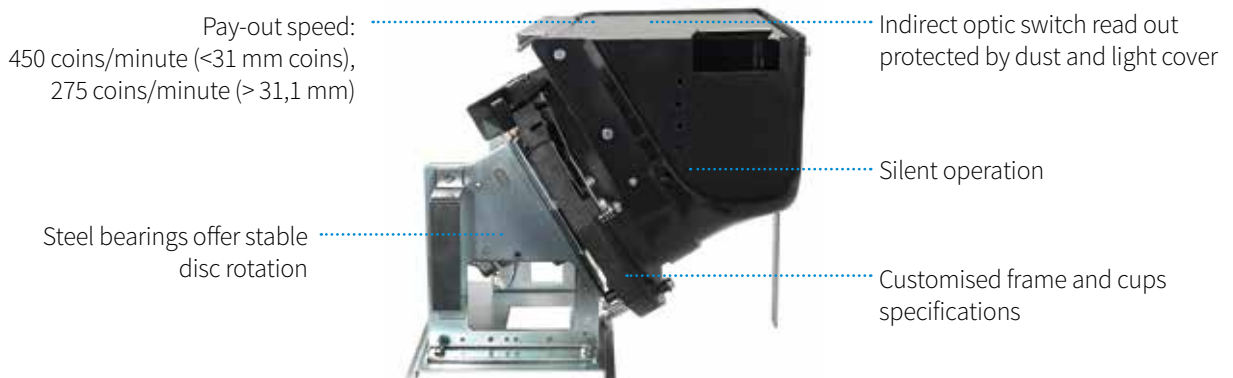

MFL®

Industry's most reliable, secure, modular design

MFL® is the first ever front load banknote validator designed for automated cash transaction applications. MFL® provides modularity and high security due to unique multi-sensor technology. MFL® utilizes a patented alignment mechanism enabling a high acceptance rate for banknotes and barcode vouchers. Due to its robust design and higher reliability, MFL® lowers total cost of ownership, enhances protection against counterfeits and improves machine uptime.

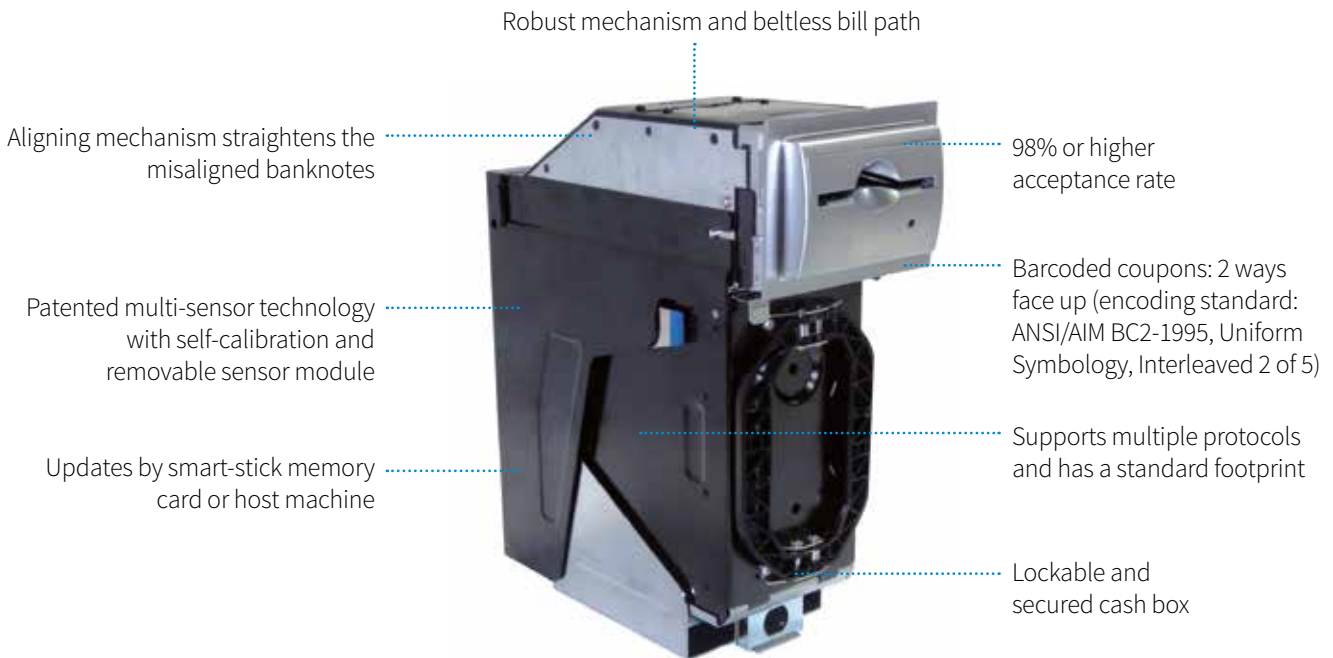

SC Advance™

Featuring enhanced recognition technology, faster note-to-note speed, and improved barcode recognition, the SC Advance™ offers a variety of cashbox options to ensure best fit. It offers a lower cost of ownership with its reliable, field proven technology. Low jam rates and exceptional performance create more machine up-time resulting in higher revenue and increased user satisfaction.



4 CASHBOX SIZE OPTIONS



Easitrax

Easitrax Soft Count offers a faster, more efficient way to validate revenue, manage cash drops and monitor the performance of your slot machines, even if they reside at multiple locations. The integrated software/hardware system works by collecting data from your SC Advance™ note acceptors and making that information securely accessible in a single database. Now, Easitrax is available as a portal-based system that allows operators to create customized reports and track performance remotely.



NV9 USB+

Enhanced sensing technology

The NV9 USB+ is the next generation banknote validator, boasting enhanced sensing technology and a high acceptance rate for multi-currency. NV9 USB+ is a versatile banknote validator with cashbox and bezel options to suit all applications. The unit can be mounted horizontally or vertically, and exceptional field reliability make the NV9 USB+ a truly global product. A note float module can be added to provide note recycling capability.

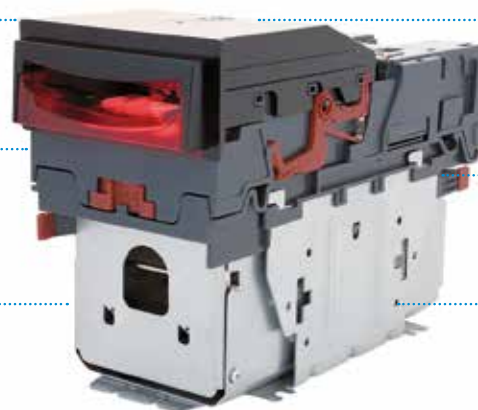

- Over 100 different world currencies accepted
- Proven field reliability
- Enhanced sensing technology = high acceptance rate for multi-currency
- Easy maintenance, free firmware updates
- Various cashbox and bezel options
- Optional note float unit

NV10 USB+

Compact stackerless banknote validator

The NV10 USB+ is a compact, stackerless banknote validator suitable for most applications. Accepting over 100 different world currencies the NV10 USB+ is a truly global product. With a field-proven validator, the unit supports industry-standard protocols and is simple to integrate and maintain.



- Enhanced sensing technology
- Proven field reliability
- Compact stackerless design
- One product supports global applications
- Simple integration
- Easy maintenance, free firmware updates
- Over 100 different world currencies accepted

Cleaning Cards



Note Acceptor Cleaning cards
29-0329-20



Card Reader Cleaning cards
29-0329-10



Thermal Printer Cleaning cards
29-0005-00

Bill-to-Bill 300™

Advanced sensors technology for Gaming applications

Bill-to-Bill 300™ is the multi-width front load bill recycler with high acceptance rates and superior counterfeit detection due to its patented technology. It is characterized by an advanced sensors technology that improves authentic bill recognition and protects against counterfeits. The validated bills are distributed between three recycling cassettes and one lockable/removable drop cassette. A maximum of 3 denominations may be directed to the recycling cassettes, with the remainder directed to the drop cassette.

98% + first time insertion acceptance rate. Acceptance speed: 2.3 seconds per banknote

Bill width validated: 67 to 71 mm wide (fixed width) and 62 to 82 mm wide (multi width), length of bill: maximum 172 mm, minimum 124 mm

Up to 3 recycling cassettes (each cassette holds up to 100 notes): "smart" cassettes save content information for easy swapping, individually configurable to any denomination

Multi-note dispenser for dispensing up to 20 notes in bulk



Industry's first self-centering mechanism

Bill acceptance: lengthwise in 4 directions

Barcoded coupons: 2 ways face up (encoding standard: ANSI/AIM BC2-1995, Uniform Symbology, Interleaved 2 of 5)

Anti-stringing protection

Up to 2 high-security locks protecting 1000-note metal cashbox contents (one additional lock to lock cashbox to device)



High acceptance rates



Multi-note dispenser



Lockable and removable drop cassette

PayCheck® NextGen™



PayCheck® NextGen™ is the 'One' printer venues need to ensure reliability, functionality and connectivity. It's the fastest printer in gaming.

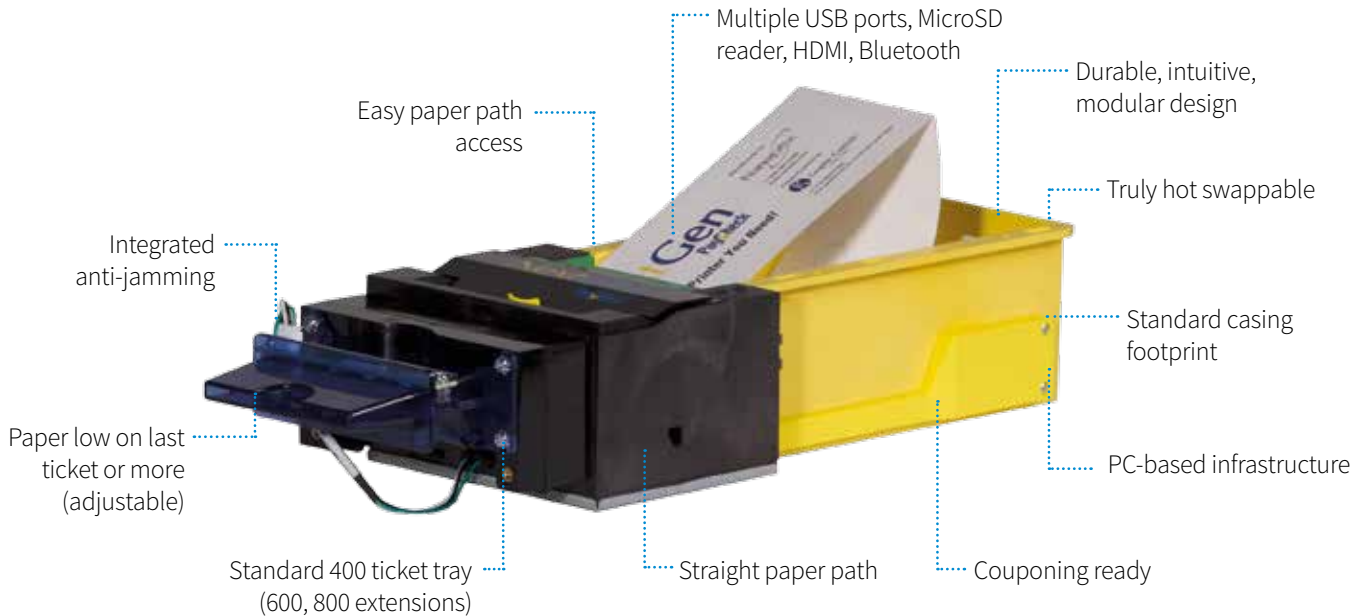

Benefits

- ✓ Better reliability and lower overall cost
- ✓ Greater customer satisfaction
- ✓ Reduces paper jams – no matter the bezel used
- ✓ Save on paper cost by no longer wasting tickets
- ✓ Use any fonts, images and logos for your tickets
- ✓ No jamming within a presenter
- ✓ Fast & easy maintenance
- ✓ Easy field service and upgrades
- ✓ Easy access to all major components
- ✓ Fast plug-and-play replacement without powering down
- ✓ Reduce downtime with larger ticket capacity
- ✓ Usable in all jurisdictions worldwide

Ticket tray note size



Multiple bezel options

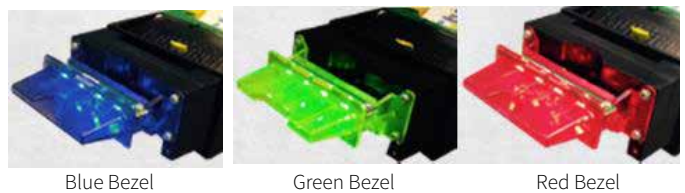

Integrated anti-jamming paper path



Easy access for simplified maintenance

PayCheck® 4™



Only the PayCheck® 4™ Thermal Printer can print a ticket in just 0.6 seconds! In fact, the PayCheck® 4™ is so lightning fast, there's no need to rely on a "burst", like some other, lesser printers do. Also, the PayCheck® 4's 8 MB of standard memory enables you to store more fonts, images, logos and barcodes, so you can personalize your players' gaming experience. With a lifespan of approximately 640,000 TITO tickets, its print head has the longest life of any in gaming.

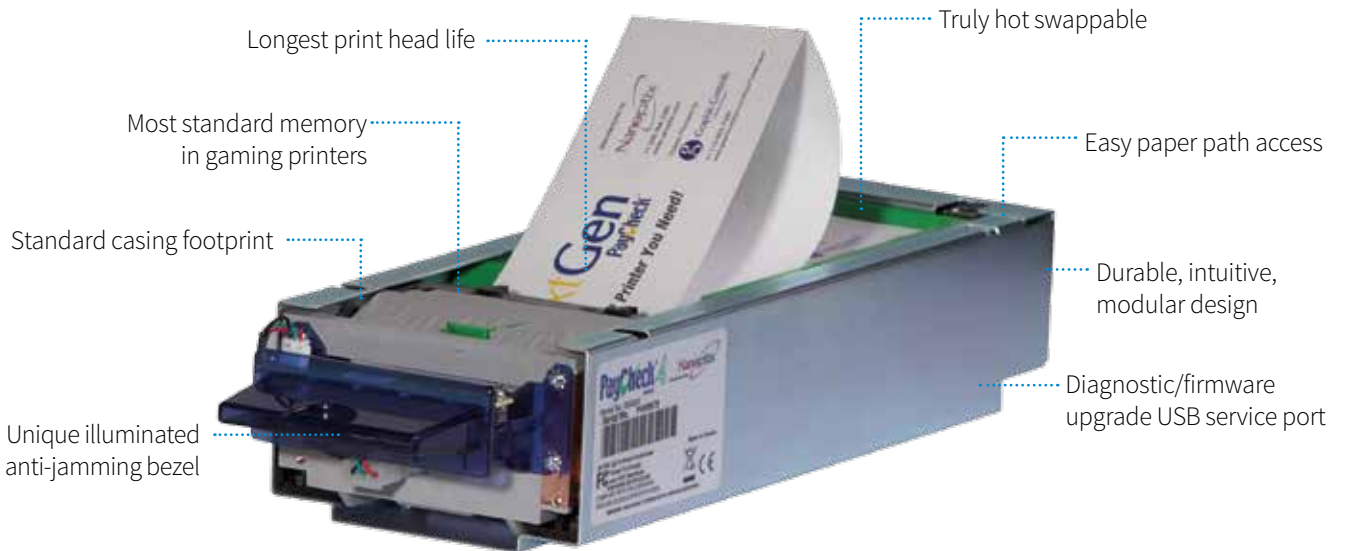

Benefits

- ✓ Greater customer satisfaction
- ✓ Better reliability and lower overall cost
- ✓ Let you personalize with fonts, images and logos
- ✓ Fast plug-and-play replacement without powering down
- ✓ Reduces paper jams for more uptime
- ✓ Fast & easy maintenance
- ✓ Easy access to all major components
- ✓ Easy field service and upgrades
- ✓ Usable in all jurisdictions worldwide

Ticket tray note size

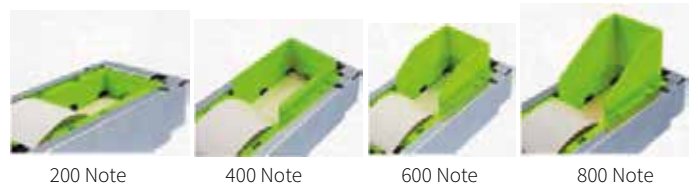

Multiple bezel options

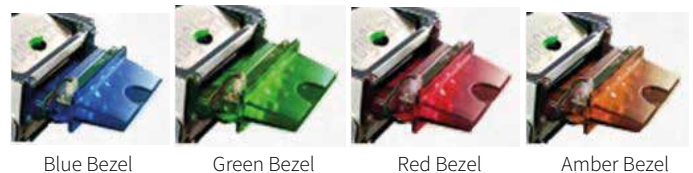

PayCheck® Terminal™



PayCheck® Terminal™ is the world's first Kiosk terminal powered by a TITO printer. Taking advantage of the power and uniqueness of the PayCheck® NextGen™ printer, we created a Linux-based terminal for your gaming, lottery and retail applications.



Benefits

- ✓ Variety of applications:
 - Validation terminal station
 - Bill to TITO printout kiosk
 - Payment kiosk
 - Players loyalty kiosk
 - PullTab kiosk
 - Self-Serve lottery terminal
 - Promotional kiosk
- ✓ SDK compatible with your GMS provider and/or marketing promotional provider
- ✓ Ideal for desktop or self-server application
- ✓ Maximizing space with its small footprint
- ✓ Networkable
- ✓ Advertise your services easily
- ✓ Reduce downtime with large ticket capacity



Secure PIN Entry Module



Paycheck® Kiosk™ with Bill Validator

HSV L Advanced™

The HSV L Advanced™ (High Speed Video Lottery) printer provides manufacturers ultimate flexibility and outstanding reliability. By using innovatively-designed movable spindle arms the HSV L Advanced can adapt to any kiosk design.

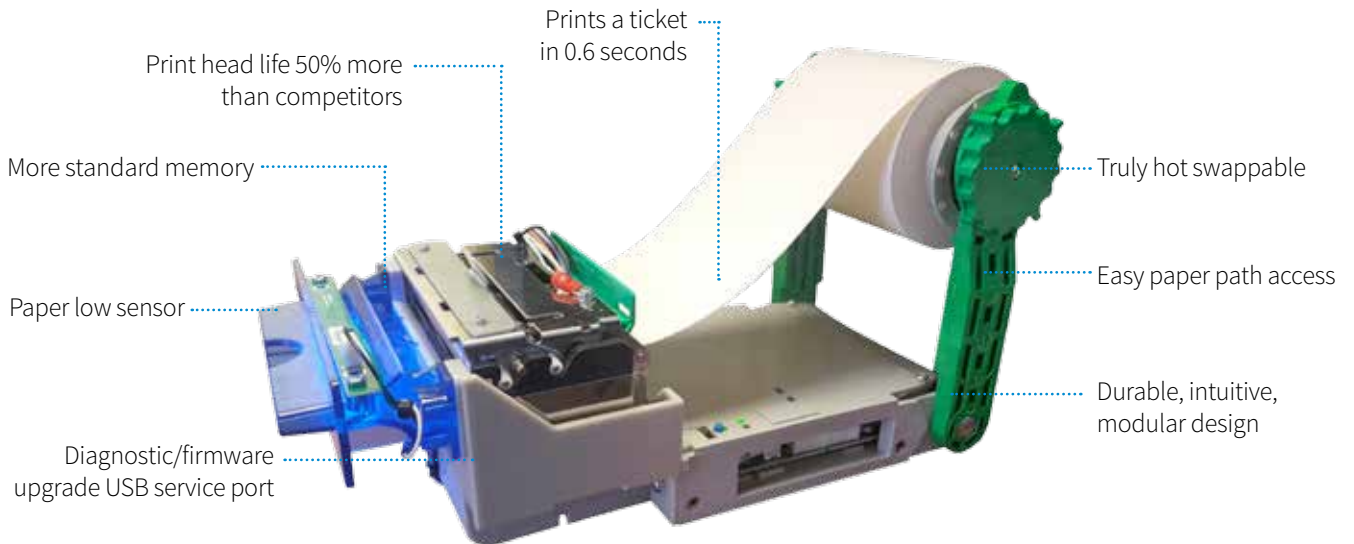

Benefits

- ✓ Greater customer satisfaction
- ✓ Better reliability and lower overall cost
- ✓ Let you personalize with fonts, images and logos
- ✓ Able to replace paper with little or no down time
- ✓ Reduces paper jams for more uptime
- ✓ Easy replacement without powering down
- ✓ Fast & easy maintenance
- ✓ Easy access to all major components
- ✓ Easy field service and upgrades
- ✓ Usable in all jurisdictions worldwide

Configurable options

- ✓ Horizontal
- ✓ Vertical (with extra bracket)
- ✓ Upside down
- ✓ Board separate

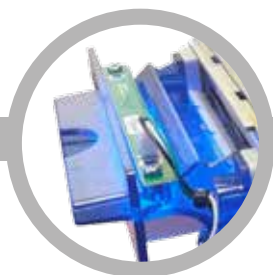

Unique illuminated jamming resistant bezel



Upside down (with extra bracket)

EZ-Tear™

EZ-Tear™

The EZ-Tear™ printer provides manufacturers flexibility while remaining compact and reliable. Built with modularity in mind, the EZ-Tear™ printer will fit many types of cabinets and with its clamshell design, provide easy access for paper loading.

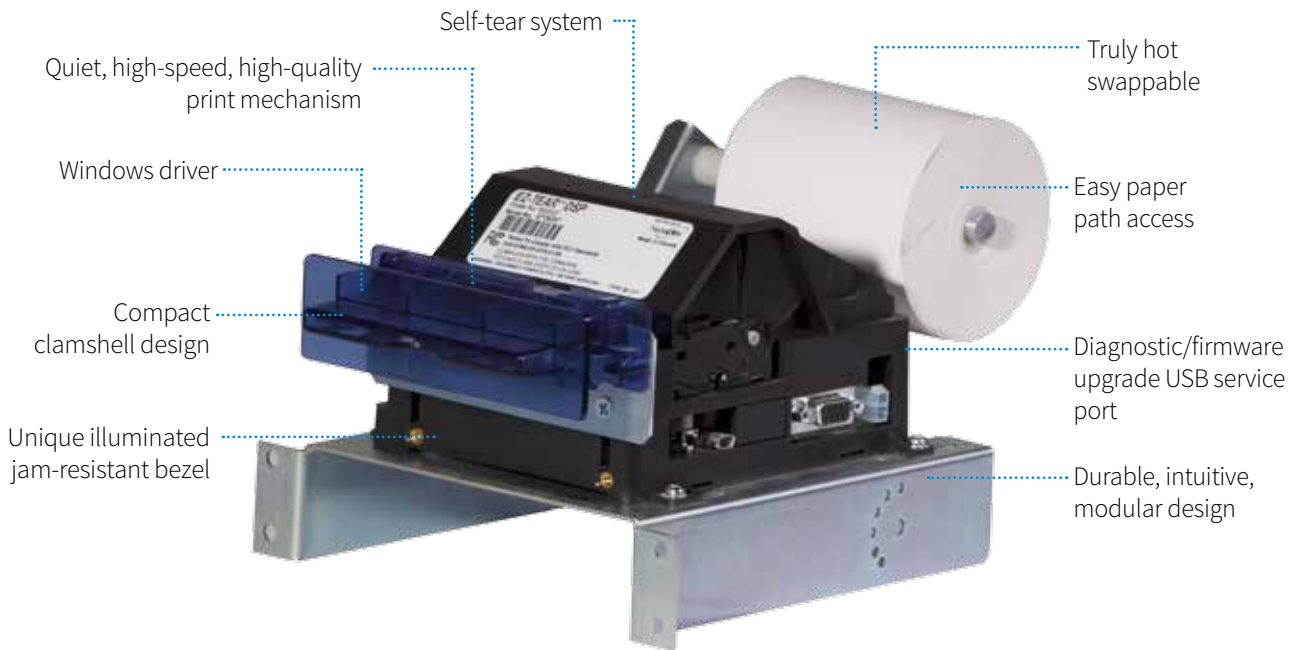

Benefits

- ✓ Lower cost of ownership
- ✓ Better reliability & customer satisfaction
- ✓ Print directly from any Windows O/S
- ✓ Provides easy paper loading
- ✓ Reduces paper jams for more uptime
- ✓ Easy replacement without powering down
- ✓ Fast & easy maintenance
- ✓ Easy access to all major components
- ✓ Easy field service and upgrades
- ✓ Usable in all jurisdictions worldwide

Configurable options

- ✓ 65 mm or 80 mm
- ✓ Compact
- ✓ Compact + Bezel
- ✓ Base Plate + Spindle
- ✓ Base Plate + Spindle + Bezel



Modular design



PayCheck® High Speed Couponing™



Specifically designed for printing promotional coupons, it prints a ticket in 1.2 seconds.

Barcodes: interleaved 2 of 5, Code 39, Code 93, UPC-A & UCP-E, CODABAR, EAN 8 & EAN 13, CODE 128

Print in sequence

64 Mbit SDRAM, 16 Mbit flash for storing code, fonts, logos, images etc.

Print head life of 100 km

Real-time operating system, DSP/BIOS

Many protocols and emulation available

Host-controllable buzzer/alarm and status indicator lights

Multiple sensor: top of form, ticket in, ticket out, ticket low

Bitmap graphics: portrait, landscape and page mode printing

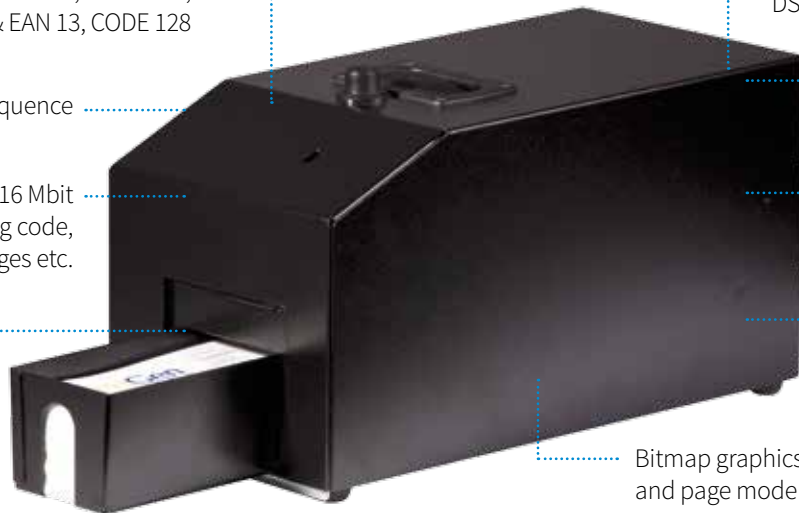

Benefits

- ✓ Easy to use configuration & diagnostic tools
- ✓ Downloadable firmware
- ✓ Supports multiple fonts and barcodes
- ✓ Rugged, intuitive design for durability and ease of use
- ✓ Power-up self-test



Lockable cover and rugged metal design



Automatically cuts and stacks 200 promotional tickets

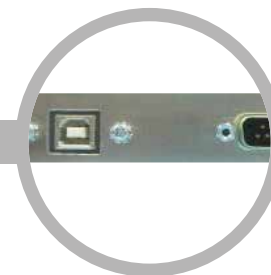

USB and serial port

“Spill-Proof” Thermal Printer

It’s fast, quiet, efficient, affordable and easy to use. Best of all, its patent-pending spill-proof design means never having to worry about OOPS again. IEC60529, IPX3 spillage approved.



“Spill-Proof Cuts” Printer

“Spill-Proof Cuts” protects your printer from potentially costly liquid spills and it also quickly and efficiently “cuts” the paper for maximum ease of use.



Slot Machines Tickets

Superior quality slot machine tickets, from blank stock tickets to customized tickets with 4-way repeat backside print. Tickets are approved for use in International Game Technology's (IGT) EZ-Pay™ and Sierra Design Group's (SDG) voucher systems.

- ✓ Unlimited colour possibilities and 4-colour printing processes provide photo realistic quality and colour reproduction
- ✓ Digital proofing systems guarantees the best match to press
- ✓ Reliable and flexible security options protect against fraud
- ✓ On-the-spot authenticity verification with thermochromic, blacklight visible UV and coin-reactive inks

Customized Tickets

Possibility to have 4 different designs on the backside of the ticket, this is a so-called 4-way repeat print, where you can choose any 4 designs which will be repeated every 4 tickets.

This is especially interesting to promote special offers from restaurants or specific games.



Barcode Scanners



1 FM100

Features

Ease of integration
Designed for OEM applications, this high performance fixed CCD scan engine can easily be integrated into various solutions such as kiosks, ticketing machines, (Reverse) Vending Machines and many more. The small form factor enables easy integration into various solutions. The FM100 has an IP54 rating meaning it is dust- and water resistant.

Advanced technology
Includes core-technology UIMG, which is independently designed and manufactured by Newland Auto-ID. UIMG technology includes the optical, CMOS, digitizer, decoder, image processing & embedded systems. The scanner supports all global standard 1D symbologies. Its reading performance reaches and exceeds global standards. By using the accessories provided, the user can ideally set up the scanner to its user environment.

2 FM430 Barracuda

Features

Megapixel camera
The FM430 Barracuda is a barcode scanning powerhouse. No matter what type of barcode is presented, the megapixel camera allows users to scan 1D and 2D barcodes, including very small ones, with impressive speed and ease.

Snappy, also in less than perfect conditions
A combination of the IR sensor and the light sensor helps to keep workers moving, even in low light conditions. Its strong, white light ensures barcodes are always well lit.

Handsfree or manual scanning
Companies looking for automatic scanning to relieve manual labor can set up the FM430 Barracuda for handsfree scanning. Alternatively, a manual trigger button can be used if preferred.

Intelligent programming
The sensors of the FM430 Barracuda automatically adjust the brightness of supplementary lighting based on the light that reflects off the barcode. This also makes it an optimal solution for scanning from mobile phone screens. Depending on the application, the scanner can be set to optimally read from close and long distance.

Reliable outdoor use
With an IP rating of 54, this fixed mount scanner can be placed in a housing and used outdoors without worrying about dust or moisture.

Bright laser aimer (optional)
The FM430 Barracuda is available with a red cross laser that makes scanning easy and intuitive, even for the most inexperienced users.

3 FM30 Grouper II Series

Features

Superior decoding performance
Your employees can scan virtually any barcode, including 1D and 2D, at an extraordinary speed.

Effortless scanning from mobile phone screen
Built to read from an LCD screen, the FM30 Grouper II Series can easily read barcodes from any mobile device screen. An extended capability of IR reading allows the device to detect barcodes under virtually any ambient light. Whether you operate at daytime or nighttime, scanning is quick and efficient.

Easily mounted in small spaces
The FM30 Grouper II Series is designed for businesses that require high performance and a minimal footprint. With its small size, the device is ideal for kiosk integration and other POS solutions.

Easy to install
The FM30 Grouper II Series can be set up quickly and easily. A plug-and-play simplicity enhances your experience right from the start. The device can be further configured according to your needs by using a simple barcode programming guide.

4 EM2037-V4

Features

Superior decoding performance
No matter what type of barcode is presented, the megapixel camera allows users to scan 1D and 2D barcodes, including very small ones, with impressive speed and ease. In addition to excellent scanning of high-density barcodes, the EM2037-V4 also provides the added value of decoding postal barcodes.

Advanced technology
The EM2037-V4 is powered by advanced imaging technology and Newland patented UIMG technology, a computerized image recognition system, can read barcodes printed on paper/plastic or displayed on mobile phones with excellent motion tolerance.

Powerful data editing capability
The scan engine allows customizing scanned data with ease and provides supporting software to address diverse application needs.

Compact & lightweight design
Seamless integration of imager and decoder board makes the scan engine very small, lightweight and easy for integration.

Various interfaces
The EM2037-V4 supports USB and TTL interfaces to meet customer needs.

Charge'N Play

Add USB Charging capabilities to your machines

Charge'N Play is the innovative dual USB charger – easy to install and simple to use, and a magnet for customers. Charges up to 2 electronic devices through the USB port. Charge'N Play can be installed in cabinets or integrated in the wall.

- 2 USB ports
- Top or side mount module
- Optional installation kit
- Designed to mount easily to wood or metal cabinet
- Optional 3-way micro-USB cable (1m length) lighting connector
- Compatible with popular mobile devices



Also available as kit, with cable, wobbler and power supply

Built-in Kit



Built-up Kit



Available with Charge'N Play

Lumia RGB Infill Panel

Features

- ▶ Pleximilchglas with RGB LED lighting and remote control
- ▶ High quality soldering iron stand
- ▶ Front panel can be easily removed (3 screws)
- ▶ Different colours adjustable, as well as various flash modes and a colour change programs
- ▶ Very discreet, non-glare lighting
- ▶ Dimensions: 95cm x 35cm x 47cm



Protec Alarm System

Features

- ▶ 12/24v DC operation
- ▶ Battery Back up
- ▶ Uses accelerometer - no external Tilt Switch necessary
- ▶ Automatic arming (if required)
- ▶ External LED indicator
- ▶ Spares available upon request



LED Light Strips



Controller & wireless remote sold separately

Attract more attention and increase your earnings!

- ▶ Easily installs in or around your machines tension and increase earnings
- ▶ Great for amusement parks and games, casinos, slot machines, arcades, family entertainment centres, theatres, backlighting, decorative lighting, etc.
- ▶ Ideal way to increase earnings on your cranes and pushers
- ▶ Very thin continuous length flexible LED light strips
- ▶ 5m rolls can be separated every 3 LEDs and reconnected again
- ▶ Super bright high-quality SMD LEDs per reel with 120° wide angle illumination
- ▶ 3M adhesive tape on back for easy installation
- ▶ Operates on +12VDC power supply (150-0072)
- ▶ Solid state, high shock or vibration resistant
- ▶ LEDs controlled by controller and wireless remote (sold separately)
- ▶ Each controller can run 65.62 feet (20 meters) of LED strips
- ▶ Long life: 50,000 hours
- ▶ Less power consumption than traditional lights
- ▶ No RF interference
- ▶ Sold in reels of 5m
- ▶ +12VDC; 20W

Lamps

Light PRO LED Tubes

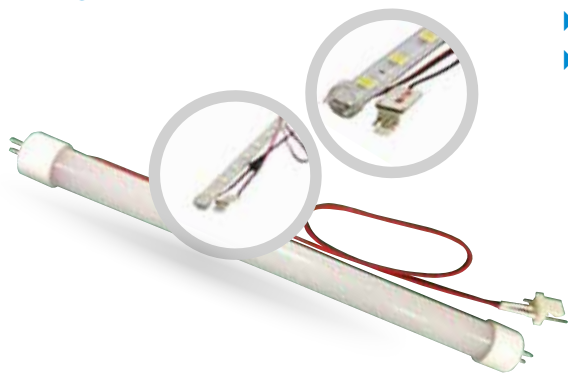

- ▶ 24V SMD LED Tube CW
- ▶ Replaces Traditional Halogen F15T8
- ▶ 24V SMD LED Fully Diffused Tube CW
- ▶ Replaces Traditional Halogen F15T5



| 5 mm | | 10 mm | |
|------------|--------|--------------|--------|
| 161-212052 | Red | 161-212103-2 | Red |
| 161-212054 | Yellow | 161-212103-4 | Yellow |
| 161-212055 | Green | 161-212103-5 | Green |
| 161-212056 | Blue | 161-212103-6 | Blue |
| 161-212059 | White | 161-212103-9 | White |

Crane/Pusher Lamps Halogen Lamps Open

| | |
|-----|---------|
| BAB | 12V 20W |
| FMW | 12V 35W |
| EXZ | 12V 50W |

Minimum order qty 20



GU10 BASE
12V 3W 9LED SMD
CW 40,000+ Hour Life X5109



MR16 BASE
12V 3W 60LED SMD
CW 40,000+ Hour Life X5093



MR16 BASE
12V 4 x1W LED
40,000+ Hour Life X5018



GU10 BASE
Reflector lamp 240V/3W 80 LED
40,000+ Hour Life X5098 (lots of 10)



SES LAMPS 60v 10w
#7965 (lots of 10)

Joysticks

- ✓ Supplied with microswitches with 4.8 mm or 6.3 mm
- ✓ Realistic spring action
- ✓ Available with 4 or 8 ways
- ✓ Ergonomic handle for comfortable grip



BL Locking Style Joystick

- ✓ Unique and very attractive round diamond knob design
- ✓ Shaft Locking design, easy and quick for installation
- ✓ New Shaft design for switchable Knob and anti-stealing functionality
- ✓ Special switch/PCB locking design, convenient for service and maintenance
- ✓ Made with highest quality raw materials with a competitive price
- ✓ Connection types: Switch only, switch with PCB
- ✓ Special lighted design (non-lighted model is available)
- ✓ Knob options: 43mm diamond ball with bubble, 43mm diamond ball without bubble, 35mm solid round ball (red /black)
- ✓ Suitable to be used for various machines

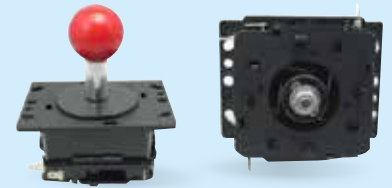

Switch structure



Switch with PCB



Switch with PCB and LED light

Trackballs

- ✓ Exceptional performance
- ✓ Custom colours available
- ✓ No external power supply needed
- ✓ Ease of use



Driving controls

- ✓ Sturdy 2 position shifter
- ✓ Microswitch operation
- ✓ Standard mounting



- ✓ Steering Wheel
- ✓ Ball bearing construction
- ✓ Potentiometer control
- ✓ Standard mounting



Speakers & Amplifiers

A wide range of speakers with terminals perfect for use anywhere a small footprint speaker is needed. Available in various sizes and voltages.



Power Supplies

200W, 400W and 500W

SUZHAPP has the power supplies you need, now featuring label and connector artwork on our website, to ensure you get the right power supplies every time.



Counters

SEC Starpoint Electronic Counter

Enhanced security is a major feature of the SEC, a unique fingerprint code allows the machine to detect any meter changes and to prevent operation if the meter is not present. By utilizing the latest electronic technology, the SEC avoids the reliability problems and service call-outs which can be experienced with mechanical counting devices.

- ✓ Replaces up to 31 mechanical meters with individual counters stored in EEPROM
- ✓ 7-digit LCD for displaying contents of counters
- ✓ Text messages and counter selection controlled by host machine
- ✓ Clocks serial interface designed to work on existing meter ports
- ✓ Improved security through:
 - Secure software protocol
 - Tamperproof counters with unique fingerprint code



Door Switches

Single and Double Pole

- Choice of push and push-pull interlock switches
- Snap-in panel mounting
- Long-life coil spring, snap-action mechanism
- Temperature rating -40° to +85°
- Flammability rating UL94V-0
- Various approvals available
- Detailed datasheets available

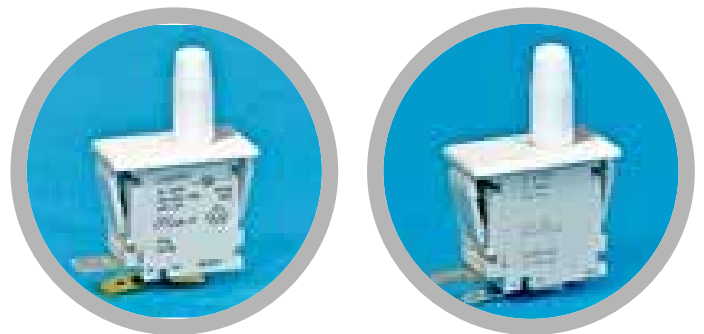

Cooling Fans

DC Cooling Fans

- Compact cooling fans
- Wire connection
- 12 or 24 Vdc
- Speed up to 5800 RPM



AC Cooling Fans

- Protects electronics from overheating
- Easy mounting with 4 bolts
- Terminal or wire connector
- Speed up to 3000 RPM



Finger Guards for Cooling Fans

- Protects electronics from over heating
- Easy mounting with 4 bolts



Compact RGB Handle Mechanism



- ✓ Ultra low-profile design allows for external mounting on cabinet and provides increased space inside of the cabinet
- ✓ Easily to remove for improved serviceability
- ✓ Ruggedized die cast design to provide long-term performance
- ✓ RGB attract mode on handle mechanism cover to attract additional attention
- ✓ As handle is pulled LEDs light up with each of the six clicks of the handle movement. All LEDs light up when handle is fully pulled
- ✓ Pre-programmed with unique flashing patterns and colour combinations
- ✓ RGB illuminated mechanism ball with 2 multi-colour LED's that flash, glow or flash light patterns to further trigger your interest in your handle machines
- ✓ 45° rotation

Flip Card Unit



- ✓ Available in two standard sizes for machine flexibility
- ✓ Provides a full deck of cards plus face cards and jokers
- ✓ Driven by standard 12V, 24 step NMB stepper motors
- ✓ Three motor steps per card
- ✓ Designed to include movement detection
- ✓ Separate mounting cradle for ease of machine assembly and service
- ✓ Units can be stacked together or mounted individually
- ✓ Card illumination via RGB LEDs
- ✓ Cards can be driven by the host or through the SUZOHAPP driver board

Custom Reel Mechanisms



Custom Engineered Reel Mechanisms to Fit the Needs of Our Customers

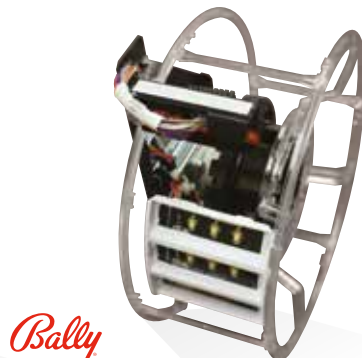
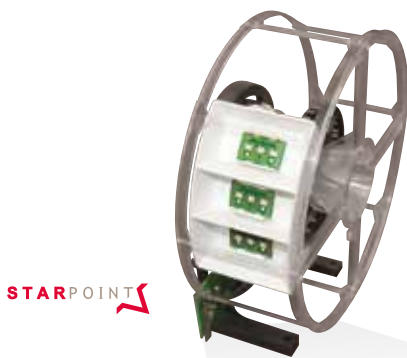

E-PRL

Electronic Re-Programmable Lock

Innovative, patented lock using electronics to raise the level of security from mechanical technology. E-PRL is a locking system composed of universal locks with stainless-steel housing and self-powered key sets. It is available in Unique-code or Multi-code versions and includes remote access control management with dedicated GSN-KEY software. No wiring is required for installation and operation.

Features

- Use of steel in all mechanical parts (AISI 316) to stop forced entry and limit wear
- Resistant to water and dust for outdoor applications, IP65 sealing
- No reference on lock for burglary – listing key pair difficult to use in burglary attempts
- Upgrade to E-PRL without modifying existing mechanicals – lengths and diameters of realization stators compatible with existing mechanical version
- No addition or change to wiring on machines with mechanical locks as power is internal to the key
- Modern ergonomic key for comfortable use – dimensions reduced to bare minimum with a harmonic shape
- High-quality Japanese key electronic components
- Inviolable AES 128-bit custom communication system
- Over 10 billion possible key codes due to the electronic system
- Uniqueness of a single key – each key has its own “DNA” derived from on-board electronic data
- Uses a small, easily changeable, long-life Duracell 2430 battery
- Lock stores up to 4,000 accesses between downloads
- High storage capacity of History Key enables storing multiple access locks with a single instrument. The History Key allows downloading and storing up to 32,000 accesses managed through dedicated software

Backward compatibility
The fixing hole, length and rotation of the lock makes it compatible with the most popular machines on the market

Innovation
It's equipped with self-powered advanced electronic technology. No additional wiring is required



Access control
It identifies each user, checks the permissions and records each operation. The event log can be downloaded using a special key

Security
High mechanical strenght, stainless steel housing and electronics with more than 10 billion combinations available, practically endless!

Optional features



Bluetooth Connectivity



Event sharing with other software

ASSA Desmo Locks

Desmo Casino Locks

With many of the world's largest casino groups as a customer the product has become a standard for any casino operator who insist on maximum security combined with maximum operating comfort. The Assa Desmo is a patented lock construction based on direct drive pins (no spring operation) making it particularly suitable for many operations in dirty and hostile environments. False cuts on the pins provide resistance to any currently known method of picking. The Assa Desmo system is the effective way to prevent unauthorized manufacturing, cutting and distribution of key blanks, it also requires the most advanced and precise key cutting equipment in the lock industry.

- 8-pin lock combined with two strong side bars
- Large key made of nickel silver for lasting durability and comfortable operation
- Standard 90 degrees operation and key removable in locked position
- Various collars available to adjust any mounting depth
- Standard supplied with 32 mm cam, other sizes and models available
- Key-different locks are supplied with 2 keys per lock

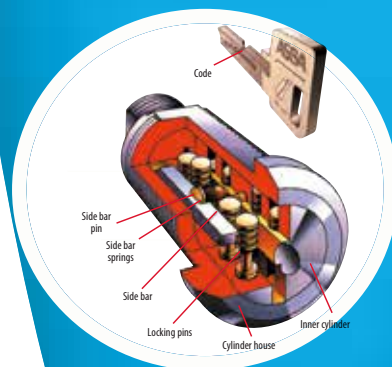

VENIA Locks & Keys

Venia Security Switchlocks DPST



- ✓ 14 pin system, 10 pins on the flat key side and 2 side pins on each side
- ✓ Brass housing with high-quality spindle and bright chrome finish
- ✓ A security collar is included with every Venia lock to prevent any attempts to turn the lock with tools
- ✓ Key made of nickel silver assures longer lifetime and trouble-free operation
- ✓ Only available as key different
- ✓ Connection by 4 solder terminals
- ✓ 2 different switch configurations: pos. 1-3 on/off, pos. 2-4 off/on

Venia Security Camlocks



- ✓ 14 pin system, 10 pins on the flat key side and 2 side pins on each side
- ✓ Brass housing with high-quality spindle and bright chrome finish
- ✓ A security collar is included with every Venia lock to prevent any attempts to turn the lock with tools
- ✓ Key made of nickel silver assures longer lifetime and trouble-free operation
- ✓ Camlocks are available in 3 different lengths: 16 mm (5/8"), 22.3 mm (7/8") and 28.6 mm (1-1/8")
- ✓ Standard 2 position 32 mm cam included

Venia Security Switchlocks



- ✓ 14 pin system, 10 pins on the flat key side and 2 side pins on each side
- ✓ Brass housing with high-quality spindle and bright chrome finish
- ✓ A security collar is included with every Venia lock to prevent any attempts to turn the lock with tools
- ✓ Key made of nickel silver assures longer lifetime and trouble-free operation
- ✓ Venia switchlocks are available with and without automatic key return

Venia Keys



- ✓ Venia keys can only be ordered through SUZOHAPP
- ✓ Key made of nickel silver assures longer lifetime and trouble-free operation
- ✓ These keys can be cut to your specific key code

Xlocks & STC Locks

Security Camlocks Key Alike



- ✓ 10 pin operation
- ✓ Die cast housing with chrome finish
- ✓ Camlocks available in 3 lengths: 16 mm (5/8"), 22.3 mm (7/8") and 28.6 mm (1-1/8")
- ✓ Large key provides good grip during operation
- ✓ Key made of nickel silver material for trouble-free performance
- ✓ Standard supplied with 32 mm cam with dual hole so the lock can be mounted in any position

Security Switchlocks



- ✓ 10 pin operation
- ✓ Die cast housing with chrome finish
- ✓ Length 36.4 mm (1-7/16")
- ✓ Large key provides good grip during operation
- ✓ Key made of nickel silver material for trouble-free performance
- ✓ Switchlocks have 6.3 x 0.8 mm terminals fitted for easy connection
- ✓ Switchlocks are available with or without automatic key return

STC Round Key Camlocks

High reliable range of camlocks of different sizes to satisfy customer needs. Locks are available both as key different

- | | |
|------------------------------|---|
| ✓ 7-pin tumbler lock | ✓ Available as key different and key alike |
| ✓ Housing with chrome finish | ✓ Available in: 16 mm (5/8"), 22.3 mm (7/8") and 28.6 mm (1-1/8") |
| ✓ Round chrome plated key | ✓ Cam included |



All new key alike series are supplied in lots of 25, 50 or 100 pcs with a total of 5 keys per key code. Re-orders on the same key code are possible with a minimum of 25 locks per key code.

Security Bars

Universal Security Bar

- | | |
|---|---|
| ✓ Designed to be used with a padlock (not included) | ✓ Supplied complete with hardware |
| ✓ Heavy duty steel | ✓ Not recommended for pedestal cabinets |
| ✓ Telescopic adjustable 40 - 85cm | |



Adjustable Security Bar

- | | |
|--|---|
| ✓ For Changers, small Cabinets and other games | ✓ Made from durable steel with black finish |
| ✓ Adjustable from 25 to 40 cm | ✓ Simple mounting with provided hardware |
| ✓ Easy installation | ✓ After installation, only a 12 mm hole needs to be drilled in hasp to fit padlock (not included) |



Specially designed for all types of Coin Operated equipment

Zenith

- ▶ Eco leather fire-retardant, water-proof, stainproof (certificate 300,000 cycles anti-abrasion)
- ▶ Padded ergonomic polyurethane foam to varying hardness
- ▶ Base: chrome diam.500 mm conical reinforced steel
- ▶ Swivel and up & down 58 cm to 84 cm (suitable for both slant top and high cabinet both)
- ▶ Base is 55 diameter - maximum height of backrest is 103 cm (minimum) and 128cm (maximum)
- ▶ Seat Auto-return 360 degree with auto-centreing breaking friction
- ▶ Finished chromium
- ▶ Exceeded the following tests and certifications: durability test, seat and back drop test, footrest fatigue resistance, resistance to fatigue armrest, stability test



Zenith4
Base chromed steel in 4 legs

The Carrillo

- ▶ Eco leather fire-retardant (certificate 300,000 cycles wear resistance)
- ▶ Padded ergonomic polyurethane foam to varying hardness
- ▶ Structure in reinforced steel with welding anti-break
- ▶ Finished chromium (three chromium)
- ▶ Available in height 73 cm for high cabinet or 55 cm ideal for slant top
- ▶ Exceeded the following tests and certifications: durability test seat and back - drop test - footrest fatigue resistance resistance to fatigue armrest - stability test
- ▶ Personalised artwork available



The Carrillo

Bebe Carrillo



39-0084-1

39-0084-1A

Available in two sizes

Apollo

- ▶ 360° rotation
- ▶ Adjustable seat height
- ▶ Free running backrest
- ▶ The six flat double wheels cannot be seen due to the cover and can support a load of 300 kg. Ideal for carpets and hard flooring
- ▶ With its teflon gliders, the chair slides smoothly over the floor without damaging it. Even when heavily loaded. No scratches, no streaks or other mark
- ▶ Spare parts are fast delivered and are quick and easy to replace



Redemption Tickets & Dispensers

Deltronic Ticket Dispenser

- ▶ “Snap out” one ticket dispenser – replace it with another in seconds
- ▶ No tools necessary
- ▶ Fool proof braking system is easily adjustable
- ▶ Validation “Diamond” mark identifies tickets
- ▶ Available as Continuous or Pulse type

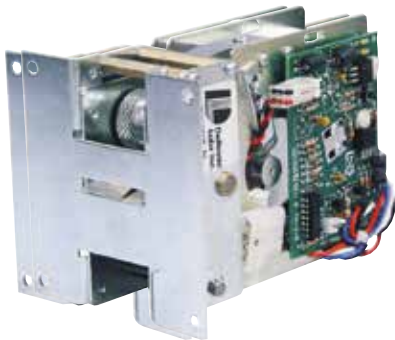

ENTD-2000 Ticket Dispenser

- ▶ Virtually eliminate ticket jams
- ▶ Requires very little maintenance
- ▶ One of the most reliable and compatible ticket dispensers on the market

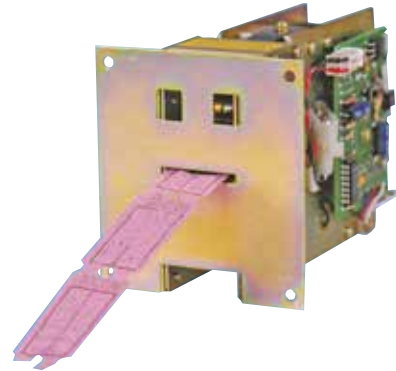

Tickets can be personalized to your requirements

Coin Cups & Holders

- ▶ Cost efficient
- ▶ Made from strong, durable, impact – resistant plastic
- ▶ Stack easily, won't stick
- ▶ Available in 2 sizes
 - 300cc (D=100mm, h=60mm)
 - 500cc (D=115mm, h=70mm)



CUSTOMISE YOUR CUPS

Just send us your logo and any ideas you might have and for a small set-up charge you can have your cups customised to your design

Air Hockey Puck Twister

- ▶ Available in 70mm and 80mm diameter
- ▶ 4 neon colours: orange, white, yellow and blue
- ▶ Colours light up when black light tube is used
- ▶ Customer logo available to order (minimum 1000 in one colour, one time tooling cost applicable)
- ▶ 70mm pucks



30-0070-3301 Orange
 30-0070-4401 Yellow
 30-0070-6601 Blue
 30-0070-9901 White

Air Hockey Hammer

- ▶ Universal Hammer for all air hockey games
- ▶ Made of durable material
- ▶ High profile handle to prevent injuries



30-0041-6 Blue
 30-0041-7 Pink

Felt Disc

- ▶ Replacement felt disc for Air Hockey Hammer 'Pro'
- ▶ Not suitable for BC1010-1

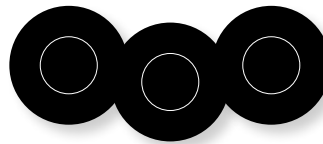

30-0030

'Kick It' Football & Tether



AI0225 Tether
 AI0189 Football

29" Pump Action Shotgun for Bick Buck Hunter Pro



96-0476-13
 29" Pump Action Shotgun, Green
 96-0476-17
 29" Pump Action Shotgun, Orange

Basketballs

- 49-0471-00 – 7" Orange Basketball
- 49-0825-00 – 9" Orange Basketball
- 49-1264-00 – 7" Tri-Colour Basketball
- 49-3020-00 – 5.5" Multicolour Mini Basketball



Touch Screen Mallet

22-1947-1



Small Foam Mallets

22-1949 Red & Yellow
 22-1946-1 (longer cable 125cm)



Universal Mallet

51-5000-00



'NEON' Glassfibre Pool Cue

- ▶ Almost unbreakable glass fibre pool cue
- ▶ No added weights that can go loose
- ▶ Moulded rubber grip
- ▶ 12 mm Slip-on tip
- ▶ Available in 4 different colours
- ▶ Length 140 cm - 57"
- ▶ Very competitive pricing!

47-0069 Neon Pool Cue Black
 47-0069-4 Neon Pool Cue Yellow
 47-0069-6 Neon Pool Cue Blue



Slip-on Tips

- ▶ Slip-on tips for the Neon Glassfibre Cues

47-1112 12 mm Push-on tips



'MATRIX' Glassfibre Pool Cue

- ▶ Besides being almost unbreakable, these Cues look like a real maple Pool Cue
- ▶ Give your players a top quality cue which will last much longer than wooden cues
- ▶ Black handle with 4-prong look
- ▶ Fitted with 12mm plastic screw-on tip
- ▶ Length 140 cm - 57"

47-0085 Matrix Pool Cue



Screw-on Tips

- ▶ Selected leather on quality plastic M8 thread with 12 mm tip used on most popular 1 piece cue

47-1230-6 12 mm Screw-on tip

'MAPLE' Pool Cue

- ▶ Fitted with 12mm plastic screw-on tip
- ▶ 4-prong brown handle
- ▶ Black rubber screw-on bumper
- ▶ Weight approx. 550gr
- ▶ Length 140 cm - 57"

47-0083 Maple Pool Cue



Plastic Screw-on Tip 12mm

47-1230-6 Screw-on tip

Rubber Bumper

47-1310 Rubber bumper



8-Ball 'MAPLE' Pool Cue

- ▶ Top quality maple pool cue
- ▶ Fitted with 13mm leather glue-on tip
- ▶ 4-prong brown handle
- ▶ 8-ball logo embedded in handle
- ▶ Assorted weights
- ▶ Length 140cm - 57"

26-1633-00 8 Ball Maple Pool Cue



"Elk Master" Glue-on Tips

- ▶ American made soft blue leather tips
- ▶ Made of special treaded leather
- ▶ Ensured grip and long life time

26-1073-13 Glue-on tip 13mm



Ash Snooker Cue

- ▶ Quality ash snooker cues
- ▶ Fitted with 9mm glue-on leather tip
- ▶ Available as 1 pc cue in 2 different colours or 2 pcs with brass joint
- ▶ Length 140cm - 57"

- 47-0155 1 pc tan butt
- 47-0156 1 pc dark butt
- 47-0273-9 2 pcs 57" Ash Cue
- 47-0273-48 2 pcs 48" Ash Cue



The Regent 2-Piece Pool Cue

- ▶ Made of Ramin wood in robust design with a solid grip, brass joint, fitted with 11mm screw-on-tip and screw-on rubber bumper

P4049 2-piece pool cue

"Elk Master" Glue-on Tips

- ▶ American made soft blue leather tips
- ▶ Made of special treaded leather
- ▶ Ensured grip and long life time

26-1073-9 Glue-on tip 9mm

Ramin Rest Sticks and Long Cue

- ▶ A complete range of rest stick, half butt cues and rests, long butt cues and rests

- 47-015 152cm - 60" Rest stick
- 47-0157-90 228cm - 90" Half butt cue
- 47-0157-108 275cm - 108" Long cue
- 47-0158-84 213cm - 84" Half butt rest
- 47-0158-96 244cm - 96" Long butt rest



Rubber Bumper

- ▶ Screw-on-rubber bumper

47-1310 Screw-on-rubber bumper

'The Shooter' Pool Cue

- ▶ Good quality ramin pool cue
- ▶ Fitted with 12mm plastic screw-on tip
- ▶ Carved black handle, painted in four prong look
- ▶ Black slip-on rubber bumper
- ▶ Sold in assorted weights
- ▶ Available in 4 different length

- 47-0052 140cm - 57"
- 47-0052-1 130cm - 52"
- 47-0052-2 120cm - 48"
- 47-0052-5 137cm - 54"
- 47-1230-6 Plastic Screw-on Tip 12mm
- 47-1320 Slip-on Rubber Bumper

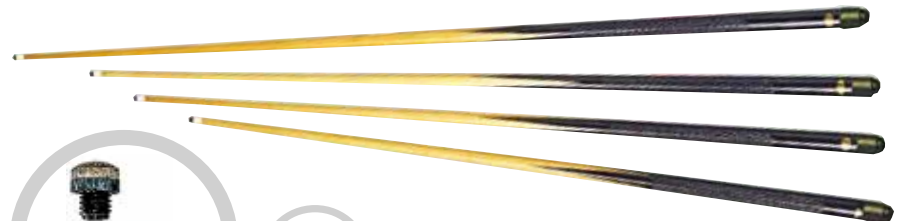

'The Regent' Pool Cue

- ▶ Good quality ramin pool cue
- ▶ Fitted with 11mm brass screw-on tip
- ▶ Black handle, painted in four prong look
- ▶ Black slip-on rubber bumper
- ▶ Sold in assorted weights
- ▶ Available in 6 different lengths

- 47-0050 140cm - 57"
- 47-0050-1 130cm - 52"
- 47-0050-2 120cm - 48"
- 47-0050-5 90cm - 36"
- 47-0050-6 137cm - 54"
- 47-0050-42 107cm - 42"
- P2270 57" non-weighted cue
- P0122 47" non-weighted cue



Brass Screw-on Tip

47-1240-4 Screw-on tip 11mm

Push-on Tips

- ▶ Standard push-on tips with bonded pre-shaped tip
- ▶ Available in different sizes
- ▶ Sold in box of 100 pcs

| | | | |
|---------|--------|---------|--------|
| 47-1110 | 11mm | 47-1114 | 13mm |
| 47-1111 | 11.5mm | 47-1115 | 13.5mm |
| 47-1112 | 12mm | 47-1116 | 14mm |
| 47-1113 | 12.5mm | | |



Billiard Pro Chalk

- ▶ Competitive price
- ▶ Sold in boxes of 12 pcs
- ▶ Available in red, green or blue

| | |
|-----------|-------------|
| 47-0650-2 | Red 0.55 |
| 47-0650-5 | Green 0.55 |
| 47-0650-6 | Blue 0.55 |
| 47-0650-7 | Purple 0.55 |



Triangle Billiard Chalk

- ▶ Top quality billiard chalk
- ▶ Sold in boxes of 12 or 144 pcs
- ▶ Available in red, blue or green

| | |
|---------------|---------------|
| 26-1023-12BT | Blue 12 pcs |
| 26-1023-12RT | Red 12 pcs |
| 26-1023-12GT | Green 12 pcs |
| 26-1023-144BT | Blue 144 pcs |
| 26-1023-144RT | Red 144 pcs |
| 26-1023-144GT | Green 144 pcs |

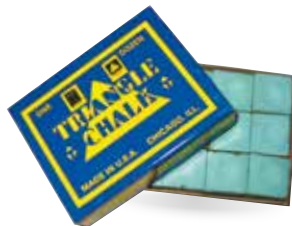

'Elk Master' Glue-on Tips

- ▶ American made soft blue leather tips
- ▶ Made of special treaded leather
- ▶ Ensured grip and long life time

| | | | |
|------------|-------|------------|------|
| 26-1073-8 | 8mm | 26-1073-11 | 11mm |
| 26-1073-85 | 8.5mm | 26-1073-12 | 12mm |
| 26-1073-9 | 9mm | 26-1073-13 | 13mm |
| 26-1073-95 | 9.5mm | 26-1073-14 | 14mm |
| 26-1967-00 | 10mm | | |



'Silver Cup' Billiard Chalk

- ▶ Strong, hard chalk grips cue tip for more accurate shooting
- ▶ Large range of colours
- ▶ Sold in boxes of 12 pcs or 144 pc

| | | | |
|---------------|-----------------|---------------|----------------------|
| 26-1051-12B | Blue 12 pcs | | |
| 26-1051-12G | Green 12 pcs | | |
| 26-1051-12BK | Black 12 pcs | | |
| 26-1051-12BUR | Burgundy 12 pcs | | |
| 26-1051-12PW | Pewter 12 pcs | | |
| 26-1051-12PR | Purple 12 pcs | 26-1051-144BK | Black 144 pcs |
| 26-1051-12R | Red 12pcs | 26-1051-144PR | Purple 144 pcs |
| 26-1051-12Tn | Tan 12 pcs | 26-0194-00 | Orange pcs |
| 26-1051-12PNK | Pink 12pcs | 26-0568-00 | White pcs |
| 26-1051-12OLV | Olive 12pcs | 26-1051-12BRN | Brown pcs |
| 26-1051-12N | Navy 12pcs | 26-1051-120P | Copper 12 pcs |
| 26-1051-12WN | Wine 12pcs | 26-1051-12EB | Electric Blue 12 pcs |
| 26-1051-12SPR | Spruce 12pcs | 26-1051-12PB | Powder Blue 12 pcs |
| 26-1051-144B | Blue 144 pcs | 26-1051-12PLM | Plum 12 pcs |
| 26-1051-144G | Green 144 pcs | 26-1051-12RB | Royal Blue 12 pcs |
| 26-1051-144R | Red 144 pcs | 26-1051-144BO | Burgandy 144 pcs |
| 26-1051-144TN | Tan 144 pcs | 26-1051-144CM | Charcoal 144 pcs |



'Master' Billiard Chalk

- ▶ Top quality billiard chalk
- ▶ Sold in boxes of 12 or 144 pcs
- ▶ Available in red, blue or green

| | |
|---------------|--------------|
| 26-1023-12R | Red 12 pcs |
| 26-1023-12B | Blue 12 pcs |
| 26-1023-12BLK | Black 12 pcs |
| 26-1023-12G | Green 12pcs |



Blue Diamond Leather Tips

- ▶ Quality Leather cue tips
- ▶ Sold in boxes of 50
- ▶ Available in blue

| | |
|---------|------|
| 47-2001 | 9mm |
| 47-2002 | 10mm |
| 47-2003 | 11mm |
| 47-2006 | 14mm |



Screw-on Tips

- ▶ Available with plastic M8 thread in 12mm or 10/24 brass thread with 10, 11 or 12mm tip
- ▶ Sold in bags of 100

| | |
|-----------|---------------------|
| 47-1230-6 | 12mm plastic thread |
| 47-1240-2 | 10mm brass thread |
| 47-1240-4 | 11mm brass thread |
| 47-1240-6 | 12mm brass thread |



Cue Tip Clamp Aluminium

- ▶ For easy replacement of cue tips
- ▶ Keeps pressure on the cue tip

| | |
|---------|---------------|
| 47-1330 | Cue tip clamp |
|---------|---------------|



Tip Fastener

- ▶ Keep pressure on the ferrule and tip
- ▶ Including compact file

| | |
|---------|--------------|
| 47-1332 | Tip fastener |
|---------|--------------|



Cue Tip Cement Tweeten

- ▶ Great for attaching leather tips to cues
- ▶ Will not harm leather tip
- ▶ Contents 2 oz / 57 grams

| | |
|------------|--------|
| 26-1107-00 | Cement |
|------------|--------|



Ferrules

- ▶ Various sizes plastic or brass ferrules

| | |
|-----------|--------------------------------------|
| 47-1261-4 | Brass ferrule 11mm |
| 47-1265 | Plastic ferrule M8 plastic thread |



Snooker Ball Rails

- ▶ Sold per set of 6

| | |
|---------|------------|
| 47-0775 | Ball Rails |
|---------|------------|



Chrome Cue Case for 2 piece Cue

P2231 Chrome Cue Case



Hard Cue Case for 2 piece Cue

47-0550 Hard Cue Case



SoftCue Case for 2 piece Cue

47-0549 Soft Cue Case



Foam Tube split Cue Case

47-0565 2 piece Cue Case



Hard Cue Case with 2 piece Cue

47-0273-90 2 piece Ash Cue & Case



Rapid Cue Top Sander

- ▶ Tool for precise preparing of the ferrule before replacing a cue tip

26-1103-00 Rue top sander



Sand Paper

- ▶ For use with the rapid cue top sander
- ▶ Sold per 10

47-0970-1 Sand paper



Slip-on Rubber Bumper

- ▶ Replacement rubber bumper
- ▶ Used on most standard pool cues

47-1320 Slip-on rubber bumper



Screw-on Rubber Bumper

- ▶ Replacement rubber bumper
- ▶ Screw mount (screw not included)

47-1310 Rubber bumper



Tip Trimmer

47-1080 Tip trimmer



Table Brushes

- ▶ Standard equipment for any pooltable
- ▶ Available in 23cm (9") or 30cm (12") size

47-1001-1 23cm (9") Brush

47-1001-3 30cm (12") Brush



Table Brush The Luxe

- ▶ 9" High quality brush

47-1002-1 9" brush The Luxe

47-1002-2 12" horsehair



Nylon Rail Brush

47-1010 Rail brush



Cue Cleaner

- ▶ Removes dirt and polishes the cue shaft

47-139 Cue cleaner



Snooker Net

- ▶ Bag type. Sold per set of 6

47-0765-2 Snooker net



Essex Straight Six Pool Mech

- ▶ This coin-mechanism is very selective thickness and diameter
- ▶ Very robust and highly flexible with respect to price-of-play change

47-0721-X Straight six
 47-0721-83 UK Industry New £1
 47-0721-81 Europe / Euro



Ratchet Spring and Pawl for Straight

47-0725 Spring and pawl



SS3228 Return Spring for Straight Six

47-0725-9 Return spring old
 47-0725-9 NEW Return spring



Rubber Chalk Holder

- ▶ Rubber holder protects chalk from damage
- ▶ Prevents chalk from being taken away

47-1050-2 Rubber chalk holder



Cloth Plasters

- ▶ Bag type. Sold per set of 6

47-1305 Cloth plasters



Brass Bridge Heads

47-1030 X bridge head
 47-1030-1 Long bridge head
 47-1030-2 Butt
 47-1030-3 Spider
 47-1030-4 Brass Swan
 47-1031 Plastic tip



Brass Heads

- ▶ Sold without toes

P5670 X rest
 P5671 Butt rest
 P5672 Spider rest



Chrome Bridge Heads

- ▶ Available as X rest or spider rest

47-1030-8 X rest chrome
 47-1030-9 Spider rest chrome



Black Plastic Pool Triangle

- ▶ These high-impact, durable plastic triangles are economical and well designed for proper ball racking

47-0700-1 15 balls 2-1/4"
 47-0700-3 15 balls 2-1/16"
 47-0700-4 15 balls 2"
 47-0700-5 10 balls 2"



Pool Table BatteryPack

- ▶ 15.6V non-rechargeable

E1168 Battery pack



Magnetic Chalk Holder

47-1055 Magnetic chalk holder



UK manufactured Dowsing Iron

- ▶ Thermostatically controlled with a temperature setting dial underneath the handle
- ▶ Supplied with a lead which is detached when ironing the table and a with a special stand on which to safely place the hot iron

47-0980



Simonis x-1 cleaning tool

- ▶ Removes chalk and dust on cloth
- ▶ Won't stretch or damage Cloth
- ▶ Non-slip handle for control
- ▶ Curved shape allows access to cloth underneath rails

P7065



Ball Tray

47-0710 Ball tray 16 balls
 47-0710-1 Ball tray 22 balls



Oak 9-Ball Diamond

- ▶ For 2-1/4" balls
- 47-0703-2 Oak 9-ball triangle



9-Ball Triangle

- ▶ For 2-1/4" balls
- 47-0703-1 9-ball diamond
 47-0700-6 9-ball triangle



Pressure Sensitive Spots

- ▶ Marking points for pool billiard
- ▶ Black textile with spot in 3 different sizes: 12, 35 and 62mm

47-1300-12 12mm spot, per 5
 47-1300-35 35mm spot, per 5
 47-1300-62 62mm spot, per 5



Pool Table Cover

- ▶ For 6ft table, With fitted elastic band
- 47-0747 Table cover



Economy Green Cover

47-0740 7 ft
 47-0745-1 8 ft
 47-0742 9 ft
 47-0743 10 ft
 P2232 12 ft

Heavy Duty Cover, Black

47-1524 7ft Table
 47-1525 7ft Table



Corner Cue Stand

- ▶ Oakwood finish cue-stand
- ▶ Holds 8 cues
- ▶ Top-shelf has cork liners for ashtray and 4 glasses
- ▶ Height 60cm

47-0502 Corner Cue Stand



Riva Cue Stand

- ▶ The low boy cue-rack, has walnut hardwood finish
- ▶ Holds 8 cues
- ▶ Height 83cm

47-0501 Riva Cue Stand



12 Cue Heavy Duty Metal Rack

- ▶ 18 gauge steel
- ▶ Baked on black powder coating
- ▶ Smooth rolled holes
- ▶ 24"(H) x 14"(W) x 11"(D)
- ▶ Weight 14 lbs

26-1461-00 NEW part number



17 Cue Metal Floor Rack

- ▶ Heavy duty - made from 1/4" steel rod
- ▶ Base - 11-3/4" x 11-3/4" Height - 24"

26-1977-00 NEW part number



12 Cue Metal Floor Rack

- ▶ Attractive black wrinkle powder coat metal finish with heavy duty brushed metal supports

26-1105-00 NEW part number



Pro-Wheeler Cue Rack

- ▶ Plastic Cue Rack for 6 Cues

47-0505-3 Pro Wheeler Cue Rack



Cue-Rack

- ▶ Wooden cue-rack for 4, 6, or 8 cues
- ▶ Solid construction with black flexible plastic cue clips
- ▶ Can be mounted to hold cues at centre up to 12" below tip

47-0507 6 Cue - rack
47-0507-1 4 Cue - rack
47-0507-2 8 Cue - rack



Black 2 piece Cue Rack

- ▶ Holds 6 cues

47-0509 Cue Rack



Cue Clip

- ▶ Black cue clip holds cues without marring

47-1385-1 Plastic cue Clip



2"-50.8mm Pool Ball Sets 1-7/8"-48mm cue ball

- 47-0822 2" Spots and stripes
- 47-0842-1 2" Reds and yellows
- 47-0842-BY 2" Blues and yellows



Snooker Ball Sets

- 47-0893 2-1/16" 22 balls
- 47-0842-Sn 2" 17 balls



Pool Balls 2"-50.8mm

- 47-0802-2 Red ball 2"
- 47-0802-4 Yellow ball 2"

2-1/4"-57mm Crazy 8 Ball

- ▶ Never follow the desired direction

47-0090 Crazy 8 ball

Cue Balls

- 47-0801-9 1-7/8"
- 47-0802-9 2"
- 47-0804-9 2-1/8"
- 47-0805-9 2-1/4"
- 47-0806-9 2-3/8"

2-1/4"- 57mm PoolBall Sets Spots and Stripes

47-0845 2-1/4" with cue ball



2-1/4"- 57mm Pool Ball Sets Reds and Yellows

47-0845-1 2-1/4"-with cue ball



8 Balls

- 47-0812-8 8 Ball 2"
- 47-0815-8 8 Ball 2-1/4"



Pool Magnetic Cue Ball

- ▶ Used in various pooltable brands like Valley and others

47-0807-9 Magnetic



Table Lighting

Billiard Lamp "Nostalgia"

- ▶ These decorative 3-pieces billiard lamps are available with a brass or chrome bar and fittings. Mounting hardware included
- ▶ Available in the following colours: red, green, blue, brass and chrome
- ▶ Overall length approx. 120cm
- ▶ Fittings are for use with bayonet lamps (not included)
- ▶ Shades and bars are supplied separately

- P5654 3-way brass bar and fittings
- P5663 3-way chrome bar and fittings
- 47-0030-2 Red bowl shade
- 47-0030-5 Green bowl shade
- 47-0030-6 Blue bowl shade
- 47-0030-C Chrome bowl shade
- P2220 Brass bowl shade
- 47-1480-1 Chain (gold)



Rules & Scoreboards



P4001 Notice Board, Superleague Pool



Pool Rules



P408 Pool Knockout Sheet (Pk 10)



Scoreboard for 2 Players
47-0603 Scoreboard



Scoreboard for 4 Players
P2250 Scoreboard

Refurb Accessories

Pool Refurb Kit

- ▶ 1 set Bed & Cushions 7x4 (Red, Green or Blue)
- ▶ 1 set balls (R&Y or B&Y)
- ▶ 1 Box Chalk (Red, Green or Blue)
- ▶ 1 12" Brush
- ▶ 1 Cloth Cleaner
- ▶ 1 Cloth Adhesive
- ▶ 1 Plastic Triangle for 2" balls
- ▶ 1 Pool Rules Sheet

REFURB-KIT-RED
REFURB-KIT-BLUE
REFURB-KIT-GREEN



Rubber Cushion

- ▶ Moulded pure gum rubber
- ▶ Sold in set of 6 pcs
- ▶ With linen protector
- ▶ Responsive cushion - attracts players



47-0761 Rubber 48" - 122cm

Economy L Shaped Rubber

- ▶ 183cm (72") length. Pink



47-0764 L shaped rubber pink

Club L Shaped Rubber

- ▶ 183cm (72") length. Black



47-0764B L shaped rubber black

Pocket Liner for Pool Table

- ▶ Colour black
- ▶ 6 pcs per set
- ▶ 4 corners and 2 sides
- ▶ Available in rubber and vinyl, 3 and 4"



47-075 3" (rubber)
47-0750-1 4" (rubber)
47-0750-2 4" (vinyl)

Gulley Boots

- ▶ Used for pool billiard
- ▶ Colour black
- ▶ 6 pcs per set



47-0756 Gulley boots

Paste on Pool Table Adhesive

- ▶ Available in 1 and 5 litre tubs



E9787 1 litre tub
E9786 5 litre tub

Pool and Snooker Cloth Cleaner

- ▶ Removes chalk and light contamination from snooker and pool table cloth
- ▶ Contents: 400 ml



20-008 Cloth Cleaner

Pool and Snooker Cloth Adhesive

- ▶ High strength adhesive with longer open bond time for large surface areas
- ▶ Tack time: 2-10 minutes
- ▶ Contents: 500 ml



20-0100 HS 300
20-0082 NC 500
20-0075 QS 900

D Marker

P5055 D Marker



Pocket Liner Screw

- ▶ Sold in packs of 50



P1139 1 Screw

Pool Table Marker Pen

47-0700c Marker Pen



Hydro Trolley

- ▶ Hydraulic
- ▶ Pool Table Trolley
- ▶ Maximum lifting weight 600 Kg



P7999

Piano Trolley

- ▶ Maximum lifting weight 600 Kg

P0142



Hydraulic Lifting Table

- ▶ Rugged construction
- ▶ Polyester powder coated hammer grey
- ▶ Large wheels for easy manoeuvrability under load
- ▶ Foot pedal operation
- ▶ Non-removable handle
- ▶ Unladen weight 26Kg

P7501

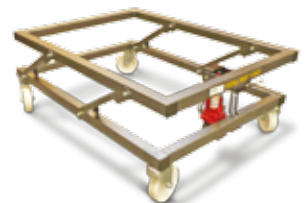

Many More Ambersil Products Available

Aerosols

A dry graphite lubricant for long lasting, smooth lock operation. The microscopic grains of graphite ensure good penetration and effective anti-seize lubrication.

- ▶ Long lasting lubrication
- ▶ Dry film does not attract dirt and grime
- ▶ Excellent water resistance
- ▶ Wide operating temperature range
- ▶ Works even when lock has mild corrosion

NEW



Take advantage of our on-site cloth cutting service ANY CLOTH! ANY COLOUR! ANY SIZE!



Strachan



The Strachan range of fine billiard and snooker cloths offer products of the highest quality, providing players with the ultimate high performance playing surface characterised by a crisp, highly engineered nap with a lustrous finish, consistent colour and high durability.

Snooker Cloth 100% wool

| | |
|------------------|--|
| 1032-GR | number 10 Championship cloth 1 meter 30 oz |
| P5965-Sn | Full Size number 10 Bed and Cushion |
| 6811GO-GR76 6811 | (Tournament) 1 meter. 30oz |
| 6811-Sn | GO Full Size Snooker Gold bed & Cushion pack |
| 6811-Sn | GOB Full Size Snooker Gold bed only |
| 6811-Sn | GOC Full Size Snooker Gold cushion only |
| 10X5PK6811 | GOSn 6811 Gold 10 foot Snooker |
| 9X5PK6811 | GOSn 6811 Gold 9 foot Snooker |

Also available in other lengths

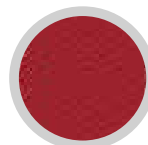

05. New Red

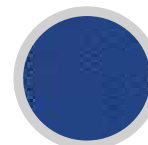

06. English Bue

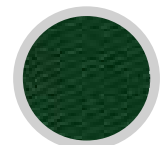

12. Olive

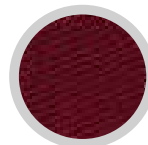

17. Burgundy

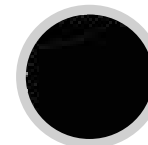

20. Black

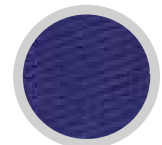

52. Purple

6811 Pool Cloth - CLUB

- ▶ 100% wool
- ▶ With Spillguard
- ▶ Weight 29oz @ 86"

| | |
|------------|--------------------------------------|
| 6811-GR86 | 6811 Pool Green cloth 1 meter 86" |
| 6811-BL86 | 6811 Pool Blue cloth 1 meter 86" |
| 6811-Bu86 | 6811 Pool Burgundy cloth 1 meter 86" |
| 6811-RE86 | 6811 Pool Red cloth 1 meter 86" |
| 6811-BLK86 | 6811 Pool Black cloth 1 meter 86" |

Available in 6x3, 7x4, 8x5, 9x5 cut packs
Part number = XXXPACK6811YY

6811 Pool Cloth - TOURNAMENT

- ▶ 100% wool
- ▶ With Spillguard
- ▶ Weight 29oz @ 86"

| | |
|--------------|--------------------------------------|
| 6811GO-GR86 | 6811 Pool Green cloth 1 meter 86" |
| 6811GO-BL86 | 6811 Pool Blue cloth 1 meter 86" |
| 6811GO-Bu86 | 6811 Pool Burgundy cloth 1 meter 86" |
| 6811GO-RE86 | 6811 Pool Red cloth 1 meter 86" |
| 6811GO-BLK86 | 6811 Pool Black cloth 1 meter 86" |

Available in 6x3, 7x4, 8x5, 9x5 cut packs
Part number = XXXPACK6811YY

6811 Tournament Cloth

- ▶ 100% wool
- ▶ With Spillguard
- ▶ Tournament cloth available in 63"
- ▶ Weight 14.5 oz

| | |
|-----------|--------------------------------|
| 6811-GR63 | 6811 Gold 63" 1 meter Green |
| 6811-BL63 | 6811 Gold 63" 1 meter Blue |
| 6811-Bu63 | 6811 Gold 63" 1 meter Burgundy |
| 6811-RE63 | 6811 Gold 63" 1 meter Red |
| 6811-Pu63 | 6811 Gold 63" 1 meter Purple |
| 6811-BK63 | 6811 Gold 63" 1 meter Black |

Available in cut packs

| | |
|-----------|------------------|
| 777-GR85 | 777 85" Green |
| 777-BL85 | 777 85" Blue |
| 777-PuR85 | 777 85" Purple |
| 777-RE85 | 777 85" Red |
| 777-BLK85 | 777 85" Black |
| 777-BuR85 | 777 85" Burgundy |

All of above available in 6x3, 7x4, 8x5, 9x5 cut packs
Part number 777-XXX-YY
(XXX= pack size 6x3, 7x4, 8x5 or 9x5 -YY= Colour code)

Eurospeed Billiard Speed Cloth

- ▶ Weight 630gr per running meter
 - ▶ Width 63" (also 79" available for English green only)
 - ▶ 45% wool 65% nylon
 - ▶ Offering to our customers a good quality range of spee cloth at an excellent price
 - ▶ Sold per meter or pre-cut packs for 6x3, 7x4, 8x5 or 9x5 Packs
- Part numbers PXXXX-YYY
(XXXX = Cloth part no YYY = pack size, for example 6x3)

Part numbers Colour

| | |
|-----------|------------------------------------|
| P5093 | Eurospeed yellow green 63" - 1mtr |
| P5094 | Eurospeed powder blue 63" - 1mtr |
| P5095 | Eurospeed purple 63" - 1mtr |
| P5096 | Eurospeed royal blue 63" - 1mtr |
| P5097 | Eurospeed English green 63" - wide |
| P5098 | Eurospeed red 63" - 1mtr |
| P5099 | Eurospeed burgundy 63" - 1mtr |
| P5100 | Eurospeed US blue green 63" - 1mtr |
| P5101 | Eurospeed black 63" - 1mtr |
| P5097-200 | Eurospeed English green 79" - wide |



SuperPro Speed Cloth

- ▶ Speed Cloth
- ▶ Spillguard finish
- ▶ 30% nylon / 70% Wool
- ▶ Supplied in 78" width in a variety of colours
- ▶ Sold per meter or cut packs
- ▶ Cut Packs Sold in 6x3, 7x4, 8x5 and 9x5

Part number = SPRO-XXX-YY
(XXX= pack size 6x3,7x4,8x5 or 9x5 - YY= Colour code)

Part numbers Colour

| | |
|------------------|-----------------------|
| SPRO-BLK78 | Black |
| SPRO-BL78 | Blue |
| SPRO-Bu78 | Burgundy |
| SPRO-EB78 | Electric Blue |
| SPRO-TB78 | Tournament Blue |
| SPRO-GR78 | Green |
| SPRO-YG78 | American Yellow Green |
| SPRO-BG78 | American Blue Green |
| SPRO-RE78 | Red |
| SPRO-Pu78 29.75 | Purple |
| SPRO-CAM78 29.75 | Tan/Camel |



Artscape™

Artscape™ is high definition, digital imaging onto premium grade, spill protected pool table cloths

Using our expertise and leading edge technologies we print unique, photo realistic designs coordinated across the bed and cushion rails. Artscape™ imaging is available on cloth made for both American and English pool. All our fabrics are manufactured to the highest quality and durability.

We have over 100 years experience in the manufacture of pool and snooker cloths. We possess the unique ability to process the printed cloth through our finishing technology to achieve the perfect playing surface whether this is a fine worsted or a fine napped finish.

Artscape pool cloths can increase table revenue by up to 40% and offer the complete solution; each is made to measure, individually packaged and easy to fit.

Our designs do not affect cloth performance or play characteristics and maintain cloth appearance for longer by minimising the effects of wear.

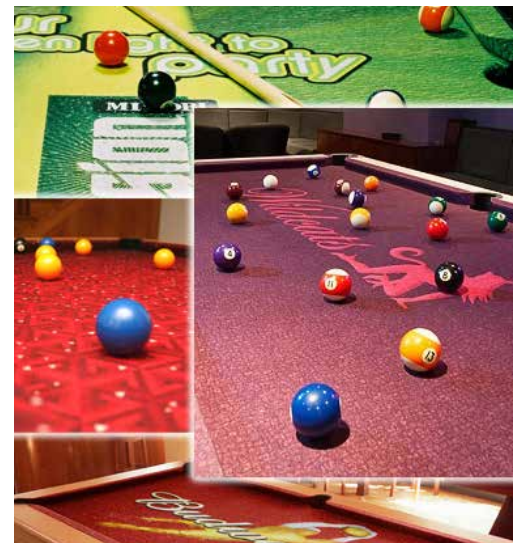

Pool & Snooker Balls

Saluc produces and distributes billiard balls under the registered trademark Aramith in more than 85 countries, and has a market share of 80% worldwide. The company is also specialised in the production of industrial balls used in all kind of applications, as well as in 9 pin bowling balls and trackballs. Export represents 98% of its activity.

One of the major strengths of the company is its upstream integration: Saluc has its own chemical plant, which produces the phenolic resin which gives the exceptional characteristics to the finished products. This integration allows the price optimization and quality insurance. The Aramith phenolic balls last up to five times longer than other balls made of polyester," said Yves Bilquin, sales and marketing manager for north America and previously the R&D manager. SUZOHAPP is a distributor and stockist of Aramith products, the full range is available although some of the less standard items may require lead times and stock.



| | |
|-----------|---------------------------------------|
| 47-0100 | Aramith Crazy Cue ball 2-1/4" |
| 47-0108 | Sapro Striped 8 Ball |
| 47-0809 | Aramith 2" Cue Ball Premier |
| 47-0098 | Aramith micro fibre cloth |
| 47-0099 | Aramith 2-1/4" TV Spots and stripes |
| 47-0610 | Aramith 2 1/4" S & S Premium |
| 47-0610-1 | Aramith 1-7/8 S&S Premier |
| 47-0610-2 | Aramith 2-1/16 S&S Premier |
| 47-0611 | Aramith 2" 1-7/8 S & S Premium |
| 47-0613 | Aramith 2" 1-7/8 S & S Standard |
| 47-0611-1 | Aramith 2" R & Y 1-7/8" Premium |
| 47-0613-1 | Aramith 2" R & Y 1-7/8" Standard |
| 47-0611-2 | Aramith 2" B & Y 1-7/8" Premium |
| 47-0611-3 | Aramith 1-7/8 R-Y Premier |
| 47-0615-8 | Aramith 2" Black Ball no.8 |
| 47-0616-8 | Aramith 2 1/4" Black Ball no.8 |
| 47-0616-9 | Aramith 1 7/8" Cue Ball white Premier |
| 47-0617-9 | Aramith 2 3/8" Cue Ball white Premier |
| 47-0618-9 | Aramith 2 1/4" Cue Ball white Premier |
| 47-0619-9 | Aramith 2 1/16" Cue Ball Premier |
| 47-0620-1 | Aramith 2 1/16" snooker set |
| 47-0620-2 | Aramith 2"+ 1-7/8" snooker set |
| 47-0620-3 | Aramith 2" 17 Ball snooker set |

| | |
|-----------|--|
| 47-0620-4 | Aramith 2-1/4" 22 Ball snooker |
| 47-0620-5 | Aramith 1-7/8" 17 Ball snooker |
| 47-0620-6 | Aramith 1-1/2" 17 Ball Snooker |
| 47-2010 | Aramith 1-3/4" 17 Ball Snooker |
| 47-0620-9 | Aramith magnetic 2 1/4" Cue Ball |
| 47-0630-1 | Aramith 2-1/4" Granite set |
| 47-0630-3 | Aramith 2-1/4" Red logo Cue Bal |
| 47-0630-7 | Aramith bar billiard set 1-7/8 |
| 47-2007 | 2-1/16" Tournament Championship snooker set |
| 47-2008 | STC 2-1/16" R/Y/W Billiard |
| 47-2009 | Sapro R&Y with Striped 8 ball set |
| 47-2009-1 | Sapro Cup R & Y 2" nylon case set |
| 47-0088 | Aramith super 2-1/4" pro-cup |
| 47-0089 | Aramith Golden 8 Ball |
| 47-0090 | Aramith Crazy 8 Ball |
| 47-0091 | Aramith Ball cleaner |
| 47-0092 | Aramith Ball restorer |
| 47-0093 | Aramith 1-7/8" Pro cup Cue Ball Premier |
| 47-0096 | Aramith 2-1/16" Pro cup Cue Ball Premier |
| 47-0097 | Aramith 2-1/4" Pro cup Cue Ball Premier |
| 47-2011 | Aramith Tournament Champion 2-1/16" Cue ball |
| 47-2012 | Aramith Glow-in-the Dark 2" Home Kit |
| 47-2013 | Aramith Glow-in-the Dark 2-1/4" Home Kit |

ICX Active-9

Coin Processing Equipment with Active Sorting® Technology

Discover the flexibility of Active Sorting® with the ICX Active-9. Eagerly anticipated, intelligent, and fresh out of the box, SUZOHAPP proudly presents the ultimate, mid-range, strong and reliable coin sorter. The ICX Active-9 is perfect for medium sized businesses, especially those wishing to process medium volumes of coin without having to worry about reliability and capability.



Features & Benefits

- Superior Coin Identification**
 Using the latest in SUZOHAPP sensor technology, the ICX Active-9 computes a specific EMS “Electro Magnetic Signature” for each processed coin. A positive coin identification requires all measured parameters to fall within predefined thresholds (coin windows). This level of accuracy allows the ICX Active-9 to precisely reject unwanted coins like other currencies, counterfeits, unfit coins or token. A maximum of 30 different coin types or tokens can be simultaneously monitored.
- Active Sorting® Technology**
 Active Sorting® technology allows the user to assign each identified coin type to a specific outlet. Since it is possible to dedicate multiple coin types (denominations) to the same outlet the ICX Active-9 can for instance separate all individual USD denominations in outlet No1-No6 while simultaneously processing all EURO coins mixed into outlet No7. Different sorting scenarios can be saved as ‘setups’ which quickly allow the processing of endless variations of multi-coin, multi-token or even multi-currency situations.

Specifications

| | |
|------------------|---|
| Speed | Up to 2,700 coins per minute (varies by currency) |
| Size (W x D x H) | 30.3” x 24.2” x 21.5” (770 mm x 614 mm x 547 mm) |

| | | | | | | | | | | |
|-------------|---|---|-------|-------|-----------------|-----------------|-------|-----------------|------------------|-------------|
| Single Step | 1 | 2 | 3 | 4 | 5 | 6 | 7 | 8 | 9 | Reject Slot |
| 1 | 1 | 1 | MIXED | MIXED | 2 ⁰⁰ | 2 ⁰⁰ | MIXED | MIXED | | |
| 2 | 5 | 5 | 10 | 10 | 25 | 25 | 50 | 1 ⁰⁰ | 1 ⁰⁰ | |
| 3 | 1 | 1 | 5 | 5 | 10 | 10 | 25 | 25 | 50 ⁰⁰ | |

DTC series

Proven sensor technology, highest reliability, extreme accuracy

Designed to satisfy the market's need for reliable and modern cash processing, the DTC Series is a strong performer in sorting and counting, as well as in rejecting foreign and damaged coins. Through the unique sensor technology these solutions offer outstanding accuracy, combined with high reliability.

Flexible choices

Depending on how many denominations you wish to count and sort, choose the DTC model that best meets your needs. The DTC-1 sorts and counts one denomination, the DTC-6 six denominations and the DTC-9 nine. An optional second solenoid can also be installed to separate a second currency or tokens.



DTC-9

9 pocket value sorter for mixed coins

Latest features and operating excellence

The touch screen display and the keypad for easy operation ensure years of operating excellence

Heavy duty coin sorter

Built in strong metal, it counts up to 520 coins per minute and sorts them into boxes. If two denominations are too close in diameter there is an option to install a second solenoid for optimal sorting

Several sorting options

It can be equipped with bag holders as well as coin tube holders

Detect foreign coins

The unit features automatic rejection of foreign and damaged coins, as well as programmable batch stops



Reliable and versatile

The latest design is made to fit in different working environments, such as banks, supermarkets, casinos, retail stores and other areas where cash is being handled

SC-303

Long-lasting coin counter

Features

- ▶ Compact and silent coin counter (counts up to 2,700 coins per minute)
- ▶ Counting, bagging and tubing
- ▶ Pre-programmable batch stops
- ▶ Handle for easy transportation
- ▶ Easy to read led display



SC-350 & SC-360

Heavy duty coin counters

Features

- ▶ Ideal to fit the gap between heavy duty machines and smaller back-office machines (counts up to 3,000 coins per minute)
- ▶ Equipped with standard RD/AuX for external display and foot control and serial interface for possibility to control machine from PC
- ▶ Counting, bagging and tubing
- ▶ Pre-programmable batch stops
- ▶ Easy to read led display



SC-8220

1+1 Pocket Value & Multi-Currency Sorter

The SC-8220 is a high quality value and multi-currency counter that delivers outstanding results at low cost. Reduce the manual cash handling and get full control of your cash!

▶ **UV LED bar**

A new patented UV LED bar placed under the machine helps manual authentication of bad notes. The UV lights turns on automatically for a few seconds when the notes are rejected.

▶ **Integration and backward compatibility**

For easy back office integration the SC-8220 is provided with its own protocol. All transactions can be seen and managed using the free software.

▶ **Front access features**

The SD-card slot is placed on the front of the machine, thus making the update of the machine very simple.

▶ **Full Flexibility for the distributor**

The SC-8220 comes with a preset of around 20 currencies.

▶ **Full Flexibility for the end user**

The SC-8220 counts and verifies one currency with ease and accuracy. It handles multi-currency in two modes to avoid time consuming and repetitive manipulations:

- 1) MULTI - it accepts different currencies in one single operation and provides a total note count split into the various currencies found within the note bundle
- 2) AUTO - it identifies the currency of the first note in the bundle and sets itself in the mode to count this currency and to reject all other currencies. As soon as the pockets are empty, the machine turns back to the auto mode for the next notes acceptance. Mixed notes of many different currencies are counted without any keyboard operation.



Specifications

| | |
|------------------------|---|
| Dimensions (W x D x H) | 275 mm x 260 mm x 319 mm (10.83"x10.24"x12.56") |
| Weight | Approx. 9.3kg (20.5 lb) |
| Speed | 800 notes per minute (serial number) 900 notes per minute (value counting) 1,100 notes per minute (free counting) |
| Interface | USB, SD Card, LAN, Serial port for printer and external display port |

SC-1600 Series

Detecting counterfeits using ultraviolet light



- ▶ Available in different security levels and note recognition modes (UV, MG, IR)
- ▶ Standard functions include continuous counting as well as variable batching of any quantity between 1 and 999 notes

- ▶ The machine restarts automatically after each completed batch to maintain high throughput
- ▶ High throughput of up to 1,500 notes per minute



Specifications

| | |
|------------------------|--|
| Dimensions (W x D x H) | 270 mm x 250 mm x 230 mm (10.6" x 9.8" x 9.0") |
| Weight | Approx. 5.7kg (12.6 lbs.) |
| Speed Range | 800/1,000/1,200/1,500 notes per minute |
| Capacity Power | 99-245 V, 50/60 Hz |

Swing

Compact cash-in machine

Suitable for any type of environment, Swing has no rivals in terms of reliability and security. Swing is secure against break-in or tampering attempts: the new cabinet, the powered locking mechanisms and the high-security side lock make it strong and sturdy. External management menu, accessible with refill key.

Features

- ▶ SD-card for programming, upgrading firmware and exporting accounting data
- ▶ High validation and counting speed: 4 coins per second
- ▶ Automatic recharge, controlled banknote recycler recharge, display of partial and total accounting
- ▶ UPS unit, with two back-up batteries, to terminate operations in progress on the cash-in machine and to record them even without electric current
- ▶ Free standing armoured cabinet



Smart Easy

Equipped with multi-coin hopper

All peripherals are integrated by means of the ccTalk communication protocol to prevent all forms of tampering and fraud. The Smart Hopper enables the change machine to be recharged with all coin denominations by simply emptying the cash box of the gaming machines into the hopper, significantly reducing the amount of cashing up time.

Features

- ▶ Multi-coin hopper capable of dispensing up to 6 types of coin
- ▶ Controlled hopper emptying into a removable tray in the base of the coin changer
- ▶ SD-card for programming, upgrading firmware and exporting accounting data
- ▶ Countertop installation with is free-standing base or Easy-UP wall mounting kit



Brain

Telemetry system

Developed in cooperation with BiTX, Brain is the innovative remote control for change machines. With Brain one or more machines can be networked and remotely controlled using PC or tablet, whilst notifications can be received on your smartphone. With a simple connection, operators can access all the information concerning accounting, alarms and master data. An email message promptly warns operators in the event of any alarms or situations that require special attention.



Easy PRO and Dual Coin PRO

The best selling change machines



Compact coin change machine which perfectly fits into all environments: shopping centres, gyms, airports, service stations, arcades, offices, bars and internet cafés.

Features

- ▶ Dispensing of one type of coin/token
- ▶ Pivoting door to facilitate dispenser-loading and cash box removal operations
- ▶ Installation on a base, a countertop or wall-mounted
- ▶ SD-card for programming, upgrading firmware and exporting accounting data

Sturdy and capacious coin change machine. Its reinforced closing mechanisms and ccTalk protocol make it one of the most secure change machines on the market. It can be equipped with the NV9 USB banknote reader with built-in stacker to stack up to 600 banknotes.

Features

- ▶ Dispensing of two types of coin/token
- ▶ Installation on a base, a countertop or wall-mounted
- ▶ SD-card for programming, upgrading firmware and exporting accounting data



Jolly PRO and Twin Jolly PRO

Robust and reliable with excellent security performance



High coin capacity in a compact size.

Features

- ▶ Dispensing of two types of coin/token
- ▶ Free standing cabinet
- ▶ SD-card for programming, upgrading firmware and exporting accounting data

Slim and versatile coin change machine.

Features

- ▶ Dispensing of one type of coin/token
- ▶ Free standing cabinet
- ▶ SD-card for programming, upgrading firmware and exporting accounting data



The IDEAL Cashless Amusement Solution

Increase revenue by going cashless

Going cashless is a great strategy for increasing sales because customers who use debit-style cards typically spend 15% more than cash customers. Customers tend to spend more when they don't have to make a buying decision each time they play a game or choose an attraction. Incentivise a larger up-front purchase by allowing your guest to load up a debit card that can be used anywhere in your facility, including any Point-of-Sale location.

IDEAL Cashless Card Arcade System combines innovative, reliable optical card-scanning technology with a double-sided barcode reader to keep customers playing, while the attractive, back-lit reader unit creates an exciting multimedia reward environment with stunning, full-motion video and sound.

Benefits

Increase revenue

- ▶ Customers spend more up front
- ▶ Customers play more freely once value is on the card

Actionable Reports

- ▶ Extensive reporting by site or by attraction
- ▶ Receive revenue snapshots via email or access on your phone

Flexibility

- ▶ Set prices in smaller increments than a quarter
- ▶ Adjust prices automatically in peak/off peak times
- ▶ Entitlements let you give rights to certain attractions
- ▶ Packages can be loaded on cards with entitlements and cash
- ▶ Supports free play, time play and discounts
- ▶ Supports cashless food and beverage service at POS locations
- ▶ Cash controls are absolute - cash added is accounted for



IDEAL Self Service Kiosks

Kiosks makes your business more accommodating

IDEAL Kiosks sell cards and add value using cash, coin, or credit card, and register cards and show history. IDEAL kiosks increase sales while simultaneously reducing labour costs. Increase your income by offering customers a self serve, always available means of purchasing or recharging game cards. Theme your kiosk with custom graphics to compliment your facility's overall look and feel. It uses a large touch-screen color display for the best guest experience. It accepts bills, coins (optional), and credit cards. It even prints receipts.

IDEAL RFID Bands Radio Frequency Identification Device

Dramatically increase the efficiency and security of any type of amusement facility by taking advantage of the benefits that RFID can provide for cashless point-of-sale, vending, access control and other guest applications. The benefits of RFID are obvious: no card, ticket or wallet is necessary for customers to have full access to ALL of the amenities in your facility.



IDEAL RCM Redemption Center Manager

IDEAL's Redemption Center Manager (RCM) provides the industry's original and most robust redemption solution. Designed to increase your arcade revenue by dramatically improving service and throughput at the redemption counter, customers spend less time waiting and more time playing. IDEAL RCM moves customers quickly and efficiently through the redemption area. It reduces labour costs while eliminating long queues and confusion at the redemption counter, solving one of the biggest challenges in any Family Entertainment Center (FEC). IDEAL RCM has the most complete inventory software on the market along with advanced control features. In addition, IDEAL RCM helps operators supervise and manage receipts, internal transfers, redemption, refunding, and inventory reporting of inventory.



Benefits

- ▶ Maintains vendor information
- ▶ Automatically calculates points values
- ▶ Guests can bank unused points into their own personal savings account or receive a bar-coded voucher for future use

Control

- ▶ Integrates with scales and ticket eaters
- ▶ Electronic inventory and processing controls

Actionable Reports

- ▶ Provides re-order reports based on sales history
- ▶ Anyone can generate actionable reports

IDEAL POS

The most complete Amusement business Point-of-Sale system

IDEAL POS is the most user-friendly and versatile software programme in the amusement industry today. IDEAL pioneered the use of software to manage and operate Family Entertainment Centers (FEC) while developing and installing the first systems in 1983.

IDEAL POS is the foundation for your One IDEAL Solution™

To build your complete One IDEAL Solution™ to manage your entire facility, we offer the most comprehensive set of software modules (e.g. Party-Scheduling, Redemption, Debit Card System, Capacity Management, eCommerce, Bowling, PDA Apps, etc.) that integrate seamlessly with your IDEAL POS.

© 2019 SUZOHAPP

All rights reserved. Specifications subject to change. 01-03-19

Trademarks owned by their respective holders.

No part of this catalogue may be reproduced in any form by print, photoprint or any other means, without written permission from the publisher.

Technical data, text and pictures are subject to error and modifications.

The catalogue can be subject to further developments.

Simplify your sourcing with our broad product range,
local resources and global capability

