

Gaming, Amusement, Sport Betting, Lottery and Bingo Solutions

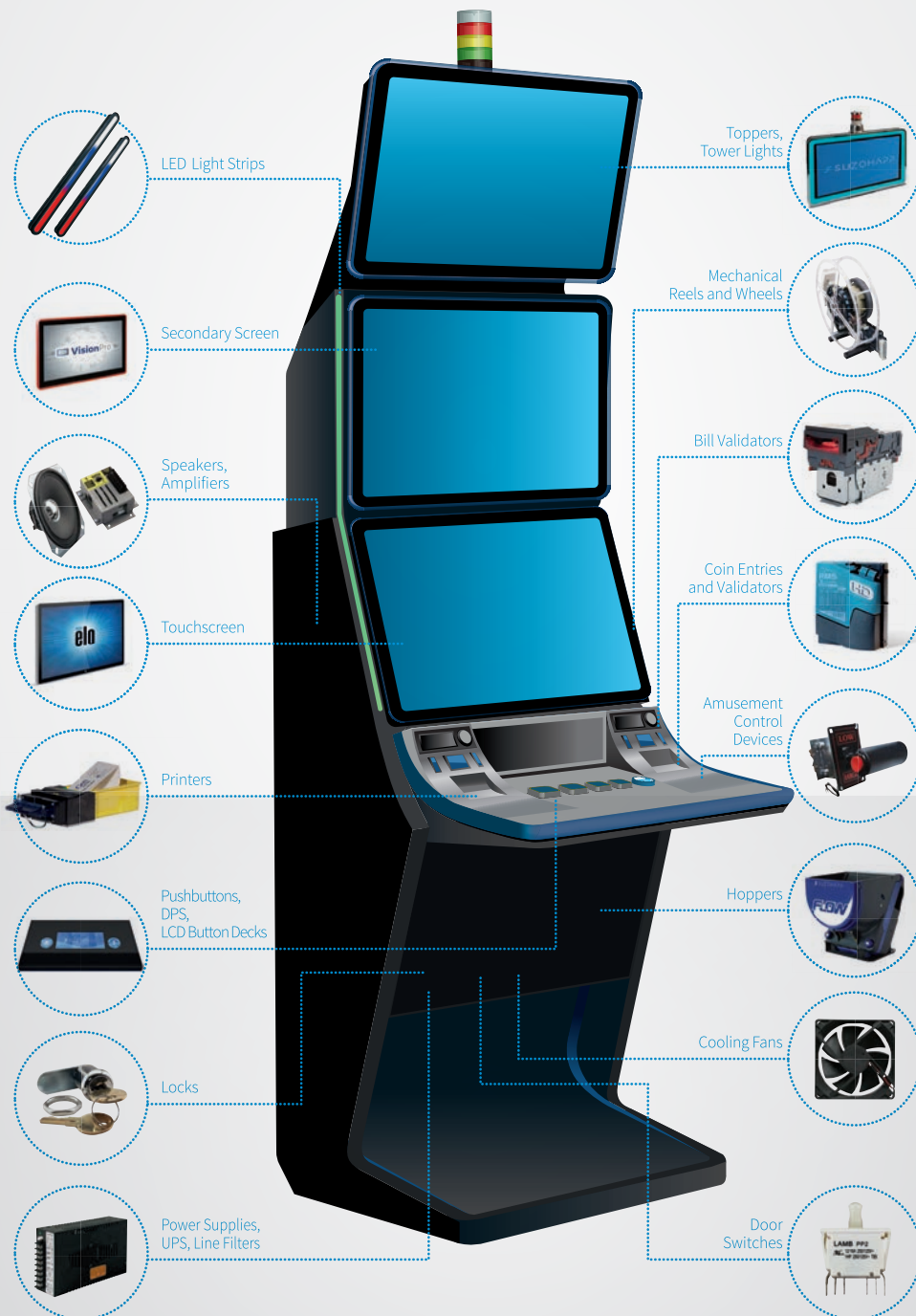



Index

About SUZOHAPP	4
Manufacturing Capabilities	6
R&D Capabilities	8

DISPLAYS

VisionPro™ LCDs	12
VisionPro™ Edge-Lit LED Monitors	14

TOUCH DISPLAYS

Elo Open-Frame Touch Monitors	16
-------------------------------------	----

TOPPERS

SH1950 Video Topper	18
RGB Mini Topper, RGB Polygon Topper	19
RGB Tower Light Topper Accessories	19
Dual-Sided LCDs	20

PUSHBUTTONS

Dynamic Panel Systems	21
Chrome-Luminescent Pushbuttons	22
Jumbo White Pushbuttons with Black Trim	23

COIN VALIDATORS

Coin Entries	24
RM5 HD	25
RM5 Evolution	25
Coin Sorters	26

HOPPERS

Cube Hopper	27
Excel Hopper	27
Evolution Hopper	28
Flow Hopper	28
ICS	29

BILL VALIDATORS

MFL®	30
SC Advance™ & Easitrax	31
NV9 USB+	32
NV10 USB+	32
Bill-to-Bill 300™	33

PRINTERS

PayCheck® NextGen™	34
PayCheck® 4™	35
PayCheck® Terminal™	36
HSVLT Advanced™	37
EZ-Tear™	38
PayCheck® High Speed Couponing™	39
“Spill-Proof” Thermal Printer, “Spill-Proof” Printer	40
Slot Machines Tickets	41

CABINET PARTS

Barcode Scanners	42
Redemption Tickets and Dispensers	43
Door Switches, Cooling Fans	43
Charge’N Play	44
Speakers, Power Supplies	45
Joysticks, Trackballs, Driving controls	46
LED Light Strips	47
Lamps, Counters	48

MECHANICAL DEVICES

Compact RGB Handle Mechanism, Flip Card Unit	49
Custom Reel Mechanisms	50

LOCKS

E-PRL	51
ASSA Desmo	52
VENIA	53
Xlocks & STC	54

SUZOHAPP

SUZOHAPP is a technology company with over 50,000 gaming, amusement, sport betting, lottery and bingo products for casino operators and gaming OEMs. Products include LCDs, sport betting solutions, toppers, hoppers, locks, coin/bill/reel mechanisms and buttons/decks. SUZOHAPP is also a leading software and hardware supplier of complete cash management solutions typically found anywhere from cashier cages to large-scale back office operations. SUZOHAPP is a global company with offices in 19 countries serving over 25,000 customers with regional delivery, local support and quick customization.



1,100+
employees



50,000+
products



35
facilities



25,000
customers



115
Engineers



Hundreds
of patents



VISION

To be the global market leader in technology-driven cash management, self-service, and gaming devices through our commitment to people, customers, and quality



MISSION

To provide our customers with excellent service and high-quality components, solutions, and software that create significant value for their business



CORE VALUES



AGILITY



CUSTOMER
FOCUS



INNOVATION



INTEGRITY



RELIABILITY



TEAMWORK

PRODUCT BRANDS

SUZOHAPP is a diverse company with multiple brands and product lines

SCAN COIN

Cash**Complete**™

Comestero

Bill**4**Bill™

currenza

coinCO

VisionPro™

CompetitionPro

BilliardPro

InteractivePro

We take pride in our products, we take care of our customers and we value our people

Global Reach

SUZHAPP is a global company with a worldwide presence and a diverse workforce. SUZHAPP has grown rapidly to meet the needs of the markets, expanding the breadth of its product offering and service capability. Its best-in-class product and service offerings create significant value and operational efficiencies for customers all over the world.

- International coverage through national subsidiaries
- Distribution partners all around the globe
- Worldwide presence with a global service network
- Variety of customers across multiple business segments



Around The World & Around The Corner

In addition to the offices and manufacturing sites located on the map, SUZHAPP has strategic partnership agreements with Value Added Distributors, Gaming Channel Partners, and Contract Service providers in those regions where market or license conditions dictate.

Your Strategic Partner

SUZHAPP's logistical support and supply chain configuration builds on its total value proposition by providing customers with cost saving delivery "From Our Door to Your Production Floor". Through continuous communication and feedback, the SUZHAPP supply chain team works closely with customers and factories to maintain a steady product supply while eliminating costly additional inventory. We are firmly committed to providing the best customer service to all customers.



Manufacturing Capabilities

Adding Value Through Manufacturing

SUZHAPP continually improves its engineering, manufacturing, service and distribution capabilities to meet the needs and exceed the expectations of its valued customers. With many years of industry experience and production excellence, SUZHAPP has developed innovative customer-centric engineering and manufacturing processes.

SUZHAPP designs and manufactures products that are used extensively in Gaming and Amusement devices as well as in demanding Industrial, Vending, and Transportation applications. In-house design, development and production resources located in multiple SUZHAPP facilities, ensure that projects are efficiently taken from concept to completion.

DESIGN & ENGINEERING

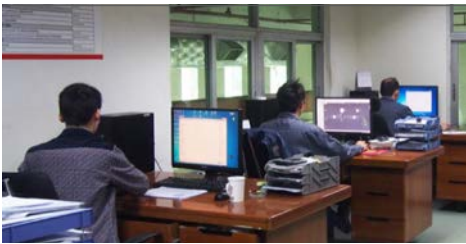

Design & Prototyping

Equipment

- CAD workstations
 - Pro/Engineer
 - SolidWorks
 - AutoCAD
- FDM prototyping machine (3D printing technology)

Capabilities

- Quick turn-around
- In-house prototyping

Resources

- 30 Engineers
 - Electrical
 - Mechanical
 - Software

LCD, TOPPERS & KIOSKS



LCD Production

Equipment

- Integrated toppers
- OEM open frame
- LCD integration
- Signage & custom assemblies
- Bid specification & RFQ

Capabilities

- 20,000 pieces per year

Resources

- 3 Engineers

PLASTIC INJECTION, TOOL & DIE



Direct Injection

Equipment

- 5 - CNC mills
- 5 - Lathes and grinders
- 1 - Wire EDM
- 28 Injection machines

Capabilities

- Sizes from 25-1,600 tons
- 20 million pieces per year
- 24-hour operation
- Insert & over-moulding
- Design to first shoot within 10 days
- 15 tools per month

Resources

- 65 dedicated staff
- +35 flex staff

PCB PRODUCTION



PCB Production

Equipment

- SMT high speed mounter
- SMT inspection
- Wave solder

Capabilities

- Surface mount
- Through-hole
- 150,000 boards per month

Resources

- 25 dedicated staff
- +15 flex staff

ASSEMBLY



Assembly

Equipment

- 12 - Conveyor lines
- 30 - Workstation cells

Capabilities

- 50 assemblies per hour, per line/cell
- Service and Repair
- Assemblies with up to 1,000 components

Resources

- 100 dedicated staff
- +100 flex staff

QUALITY ASSURANCE



Quality

Highlights

- ISO 9001
- Testing services and capabilities

Resources

- 30 FTEs in area of quality control and assurance

Manufacturing and Distribution Facilities



Manufacturing Site China

- Zhuhai, China
- 12,000 sqm
- 250 employees
- Turnkey design / manufacture
- Interactive touch displays
- Transparent LCD technologies
- Cash handling technologies
- Printers, card/barcode readers, NFC/RFID, cameras
- Kiosks, loyalty and betting terminals
- Digital signage
- LED lighting and back lighting technologies



Manufacturing and Distribution Site North America

- Mount Prospect, IL and Las Vegas, NV production locations
- Over 6,000 sqm
- Assembly, Distribution, Service and Support
- Cash Management Solutions: Note recyclers, coin recyclers, deposit safes
- Components & OEM: Joysticks, buttons, coin doors, LCDs, reel mechs, toppers, game controls



Manufacturing Site Poland

- Poznan, Poland
- Over 5,000 sqm
- 60 employees
- Components: Coin validators, coin recyclers
- Solutions: Change machines, cash points for self-service laundrettes, car wash starter systems, cash handling solutions



Assembly and Logistics Hub Netherlands

- Oud-Beijerland, Rotterdam
- 49,000 sqm
- Fully bar-coded warehousing
- Real time data processing systems
- Accurate reporting of inventory
- Excellent customer service

R&D Capabilities

Investment in research and development is a top priority

Global product management teams meet continuously to develop new products and custom solutions for customers' ever-changing needs. Dedicated industrial, mechanical, and electrical engineering teams provide complete design, as well as component selection. SUZOHAPP utilizes contemporary modelling technology to produce accurate designs with competitive costs and short lead times.

Technology Centres

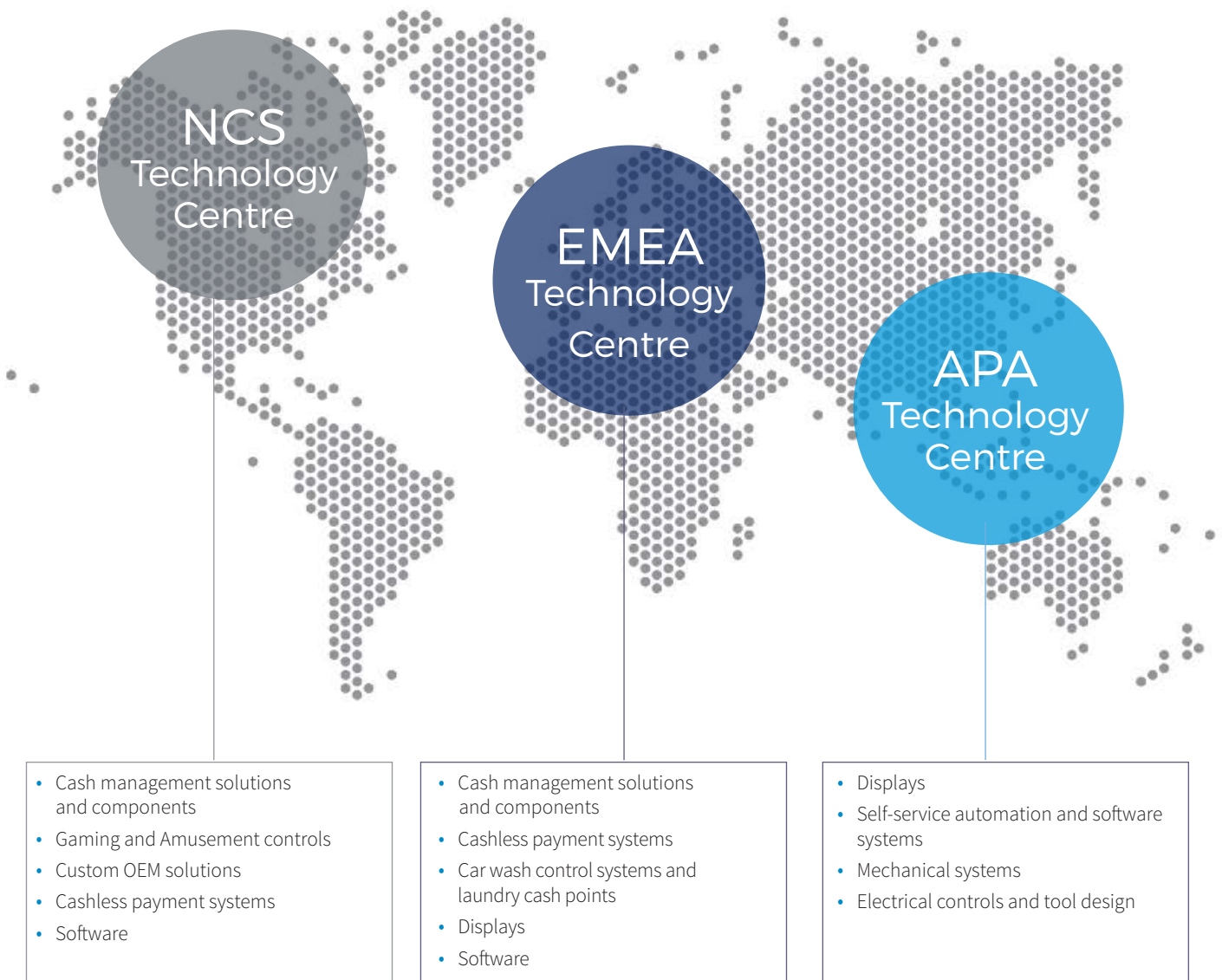

SUZOHAPP's Research & Development team is centralized into one global engineering centre of excellence, SUZOHAPP Technology Services (STS). This highly skilled department develops and supports the company's core technology, accelerates new product development and leads the introduction of innovative technologies.

Design activities and expertise provided include:

- Turnkey design/manufacture of individual parts to complete machines - from concept development through final, highly engineered solutions
- 2D and 3D CAD Design – using SolidWorks for part/assembly modelling and drawings
- Metalwork/plastic design and electrical/wiring harnesses, virtual and physical prototyping, and product renderings
- Design of injection moulds and tooling
- Rapid prototyping through in-house 3D printing capabilities
- Proprietary electronics and PCB Design using the leading software package Altium
- Programming for microprocessors and Advanced Risk Machines (ARM), software development in most operating systems including Windows, Linux and Android OS
- Compliance testing and documentation, including UL

Examples of some of the technologies SUZOHAPP works with:

- The latest LCD and touchscreen technologies, including projective capacitance
- LED lighting and back lighting technologies
- Embedded micro controllers and CPUs
- Electromechanical and mechanical systems

SUZOHAPP's dedicated team has been central to the success of many product deployments to the global amusement, gaming, industrial, transportation and vending markets.

Projects have included:

- LCD retrofit integration
- Custom designed displays, including transparent LCD technology
- Interactive touch displays, large and small
- Cash handling technologies
- Printers, card/barcode readers, NFC/RFID, cameras
- Kiosks, loyalty and betting terminals
- Digital signage

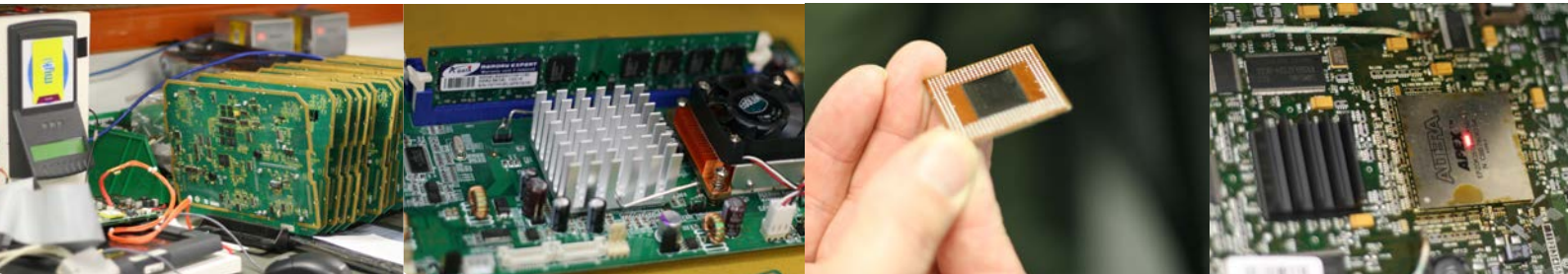

Workshop Service

Highly experienced lab technicians can repair parts to component level, utilizing the latest diagnostic equipment and techniques. SUZOHAPP can also redesign, re-engineer, restore or re-manufacture parts and components reducing your business maintenance costs.

Repair Services

- Electronic gaming machines
- Jackpot systems and player tracking hardware
- POS systems, ATMs, self-service terminals
- Cash handling – bill acceptors, coin mechanisms, hoppers
- Data scanners, PDAs, PC mainboards, logic boards
- LCD displays, touchscreens
- LCD and CRT monitors, power supplies
- Electronic assembly and manufacturing services
- Electronic kiosks
- Wagering terminals
- Other electro-mechanical assembly work

SUZOHAPP technicians are highly skilled

- IPC certified specialist technicians ensure the highest quality in surface mount, hole through and wave soldering
- Experienced in repairing multilayer boards
- Ability to perform circuit programming (FPGA, JTAG) and program microprocessors (TQFP, SSOP, EPROM)

SUZOHAPP technical experts:

- Re-work and re-flow BGA ICs
- Give logic boards, main boards and A-D boards a new lease on life
- Refurbish circuit boards for most popular gaming machines and electronic equipment
- Repair bill validators, ticket printers, hoppers and coin mechanisms, giving considerable savings compared to the cost of replacement

Simplify your sourcing with our broad product

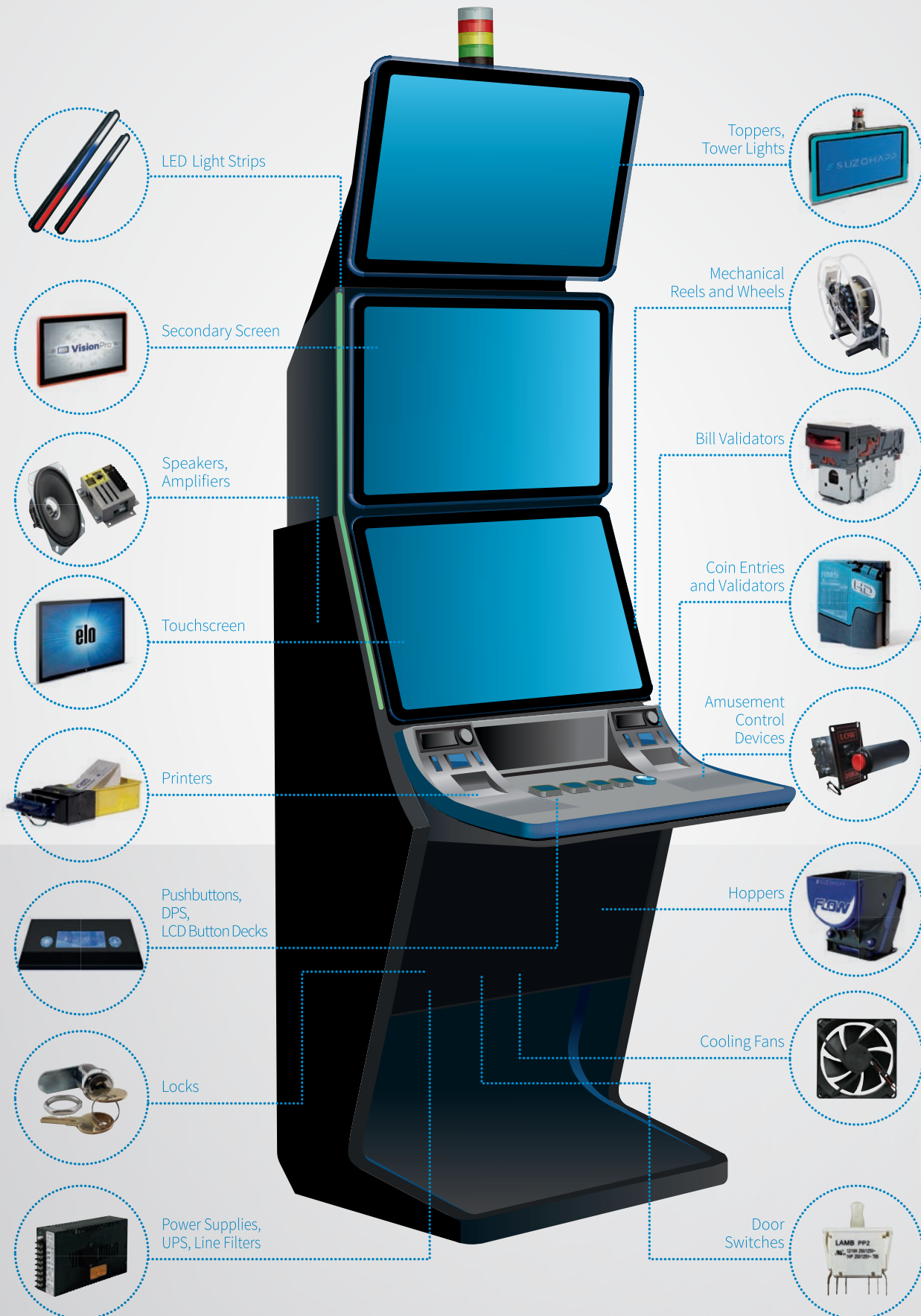

range, local resources, and global capability



High Quality LCDs for Gaming, Amusement, Sport Betting, Lottery, and Bingo

Touch and Non-Touch



VisionPro™ is SUZOHAPP's premium line of LCDs using top panel brands and high-quality boards. Fast customization is available for both OEMs and upgrades: 6.2" to 90", specialized panels and integration, customized metal, touchscreens and inputs.

Features:

- ✓ Standard sizes from 15" to 32"
- ✓ Choice of
 - 10+ touch Projected Capacitive (PCAP), true-flat, seamless edge-to-edge glass
 - 3M Surface Capacitive (SCAP) touch technology
 - Protective Glass
- ✓ Standard and wide viewing angle units available
- ✓ Common footprint for touch and non-touch variations
- ✓ DVI and VGA, HDMI and DisplayPort available
- ✓ LED options for surrounding display
- ✓ Economically priced
- ✓ 1-year standard warranty

Model	Size/Aspect Ratio	Native Resolution	Viewing Angle	Panel Brightness	Contrast Ratio	Touch/Glass	Signal Input	Edge-Lit LEDs*	LED Type	Bezel
150TFT2154	21.5" 16:9	FHD	178 x 178	250	1000:1		VGA/DP			
150FTG2154	21.5" 16:9	FHD	178 x 178	250	1000:1	Printed Glass	VGA/DP			
150FTFP2154	21.5" 16:9	FHD	178 x 178	250	1000:1	PCAP USB Touch	VGA/DP			
150LG2150	21.5" 16:9	FHD	178 x 178	250	1000:1	Printed Glass	VGA/DVI	Integrated	RGB	
150LP2150	21.5" 16:9	FHD	178 x 178	250	1000:1	PCAP USB Touch	VGA/DVI	Integrated	RGB	
150LG2152	21.5" 16:9	FHD	178 x 178	250	1000:1	Printed Glass	VGA/DVI	Integrated	Addressable	
150LP2152	21.5" 16:9	FHD	178 x 178	250	1000:1	PCAP USB Touch	VGA/DVI	Integrated	Addressable	
150DLG2150	21.5" 16:9	FHD	178 x 178	250	1000:1	Printed Glass	VGA/DVI	External	Addressable	
150DLP2150	21.5" 16:9	FHD	178 x 178	250	1000:1	PCAP USB Touch	VGA/DVI	External	Addressable	
150TFT2206	22" 16:10	1680x1050	178 x 178	250	2000:1		VGA/DVI			
150FTG2206	22" 16:10	1680x1050	178 x 178	250	2000:1	Clear Glass	VGA/DVI			
150FTS2206M	22" 16:10	1680x1050	178 x 178	250	2000:1	3M Serial Touch	VGA/DVI			
150FTS2206MU	22" 16:10	1680x1050	178 x 178	250	2000:1	3M USB Touch	VGA/DVI			
150TFT2302	23" 16:9	FHD	178 x 178	250	1000:1		VGA/DVI			Yes
150FTG2302G	23" 16:9	FHD	178 x 178	250	1000:1	Clear Glass	VGA/DVI			Yes
150FTS2302MG	23" 16:9	FHD	178 x 178	250	1000:1	3M Serial Touch	VGA/DVI			Yes
150FTS2302MU	23" 16:9	FHD	178 x 178	250	1000:1	3M USB Touch	VGA/DVI			Yes
150TFT2382	23.8" 16:9	FHD	178 x 178	250	1000:1		VGA/DP			
150FTG2382	23.8" 16:9	FHD	178 x 178	250	1000:1	Printed Glass	VGA/DP			
150FTFP2382	23.8" 16:9	FHD	178 x 178	250	1000:1	PCAP USB Touch	VGA/DP			
150LG2380	23.8" 16:9	FHD	178 x 178	250	1000:1	Printed Glass	VGA/DVI	Integrated	RGB	
150LP2380	23.8" 16:9	FHD	178 x 178	250	1000:1	PCAP USB Touch	VGA/DVI	Integrated	RGB	
150LG2382	23.8" 16:9	FHD	178 x 178	250	1000:1	Printed Glass	VGA/DVI	Integrated	Addressable	
150LP2382	23.8" 16:9	FHD	178 x 178	250	1000:1	PCAP USB Touch	VGA/DVI	Integrated	Addressable	
150DLG2380	23.8" 16:9	FHD	178 x 178	250	1000:1	Printed Glass	VGA/DVI	External	Addressable	
150DLP2380	23.8" 16:9	FHD	178 x 178	250	1000:1	PCAP USB Touch	VGA/DVI	External	Addressable	
150FTG2414	24" 16:10	1920x1200	178 x 178	300	1000:1	Clear Glass	VGA/DVI			Yes
150FTS2414M	24" 16:10	1920x1200	178 x 178	300	1000:1	3M Serial Touch	VGA/DVI			Yes
150FTS2414MU	24" 16:10	1920x1200	178 x 178	300	1000:1	USB Touch	VGA/DVI			Yes
150TFT2705	27" 16:9	FHD	178 x 178	300	3000:1		VGA/DP			
150FTG2705	27" 16:9	FHD	178 x 178	300	3000:1	Printed Glass	VGA/DP			
150FTFP2705	27" 16:9	FHD	178 x 178	300	3000:1	PCAP USB Touch	VGA/DP			
150FTFP2705S	27" 16:9	FHD	178 x 178	300	3000:1	PCAP Serial Touch	VGA/DP			
150LG2700	27" 16:9	FHD	178 x 178	300	3000:1	Printed Glass	VGA/DVI	Integrated	RGB	
150LP2700	27" 16:9	FHD	178 x 178	300	3000:1	PCAP USB Touch	VGA/DVI	Integrated	RGB	
150LG2702	27" 16:9	FHD	178 x 178	300	3000:1	Printed Glass	VGA/DVI	Integrated	Addressable	
150LP2702	27" 16:9	FHD	178 x 178	300	3000:1	PCAP USB Touch	VGA/DVI	Integrated	Addressable	
150DLG2700	27" 16:9	FHD	178 x 178	300	3000:1	PCAP Printed Glass	VGA/DVI	External	Addressable	
150DLP2700	27" 16:9	FHD	178 x 178	300	3000:1	PCAP USB Touch	VGA/DVI	External	Addressable	
150TFT3210	32" 16:9	FHD	178 x 178	350	3000:1		VGA/DVI			
150FTG3210	32" 16:9	FHD	178 x 178	350	3000:1	Clear Glass	VGA/DVI			

Notes:

- Specs and drawings, manuals, and CAD files are available upon request.
- The standard models above can be used as a basis for customization. Many other options are available i.e. video inputs including Display Port (DP), DVI, HDMI, customized touchscreens with serial or USB, customized metal, paint and logos, different panels and video resolutions, outdoor and vandal resistance options, and extended warranties.
- Please inquire for other sizes and variations.

Edge-Lit LED Monitors

Gaming Monitors with LED Frames and Halo Effect
Touch and Non-Touch



CHOICES

1 Size	21.5"	23.8"	27"
2 Design	<ul style="list-style-type: none"> • Integrated for mounting monitor flush inside your cabinet 	<ul style="list-style-type: none"> • External for floating monitor outside your cabinet with halo effect 	
3 LEDs	<ul style="list-style-type: none"> • RGB solid colour, 12V without IC 	<ul style="list-style-type: none"> • Addressable individually driven, 5V with IC 	
4 Touch or Non-Touch	<ul style="list-style-type: none"> • 10-touch PCAP 	<ul style="list-style-type: none"> • Non-touch 3mm tempered glass 	

FEATURES

- ✓ Rigid high-quality PCB-mounted LEDs, no adhesive strips, no hotspots
- ✓ True-flat design
- ✓ FHD 1920x1080, WVA 178° x 178° for landscape or portrait usage
- ✓ 21.5"/23.8": 250 cd/m², 1000:1
27": 300 cd/m², 3000:1
- ✓ 10-touch PCAP for Windows 7 or later, Linux 4.4 or later
- ✓ VGA + DVI standard, HDMI and DisplayPort available
- ✓ 12V DC or 100-240V AC (brick optional)
- ✓ Operating temperature: 0-50 °C
- ✓ CE, RoHS
- ✓ Drawings and CAD files available on request
- ✓ Customization possible

2 Design



Integrated Design

For mounting monitor flush inside your cabinet. Accent your display with a frame of colour.



External Design

For floating monitor outside your cabinet. Surround colour in front, side, rear for a halo effect.



1 Size	2 Design	3 LEDs	4 Touch or Non-Touch	Max Dimensions (WxHxD)	Part Number
21.5"	Integrated	RGB	PCAP 10-touch	21.3" x 13.3" x 2" (541.8 x 336.4 x 51.0 mm)	150LP2150
			3mm tempered glass		150LG2150
		Addressable	PCAP 10-touch		150LP2152
			3mm tempered glass		150LG2152
	External	Addressable	PCAP 10-touch	22.1" x 14.1" x 2.2" (562.6 x 357.2 x 56.0 mm)	150DLP2150
			3mm tempered glass		150DLG2150
23.8"	Integrated	RGB	PCAP 10-touch	23.1" x 14.4" x 2" (587.8 x 366.8 x 51.0 mm)	150LP2380
			3mm tempered glass		150LG2380
		Addressable	PCAP 10-touch		150LP2382
			3mm tempered glass		150LG2382
	External	Addressable	PCAP 10-touch	24" x 15.3" x 2.2" (608.6 x 387.6 x 56.0 mm)	150DLP2380
			3mm tempered glass		150DLG2380
27"	Integrated	RGB	PCAP 10-touch	26" x 16" x 2" (659.8 x 406.8 x 51.0 mm)	150LP2700
			3mm tempered glass		150LG2700
		Addressable	PCAP 10-touch		150LP2702
			3mm tempered glass		150LG2702
	External	Addressable	PCAP 10-touch	26.8" x 16.8" x 2.2" (680.6 x 427.6 x 56.0 mm)	150DLP2700
			3mm tempered glass		150DLG2700

Elo Touch Solutions Open Frame Gaming Monitors



Brilliant Display. Superior Quality. Competitive Price.

Engineered and designed specifically for the demanding requirements of the gaming industry, the 90-Series open-frame displays feature touch technology that is built-in rather than glued-on. Elo is the world leader in commercial touch with over 20 million installations, half a million units per year, nearly 2,000 units per day.

Select from a wide range of sizes from 10" to 27" to fit in any gaming environment. Other Elo products extend the range to 70".

Only Elo produces the touchscreens, controllers, drivers, and monitor for a complete solution proven in 10,000s of gaming installations.

Take advantage of these great features:

- ✓ Next generation Projected Capacitive (PCAP) 2GS technology (2 glass solution)
- ✓ Highest optical quality and longevity as no plastic films, no metal mesh
- ✓ 10-touch true-flat solution
- ✓ Thru-glass mode which operates through up to 6 mm customer-supplied glass
- ✓ Common mechanical and electrical components across the line for easy design-in, compliance testing, service, and transition between sizes
- ✓ HDMI, DisplayPort, VGA inputs, with common port design across all units
- ✓ Built-in watertight edge seal
- ✓ Magnetic tethered OSD control box
- ✓ Unique field-replaceable touchscreen glass design
- ✓ Global agency approvals: United States UL, FCC; Europe CE TÜV; Australia RCM; Canada cUL, IC; China CCC; Japan VCCI; Korea KCC; Mexico CoC; Taiwan BSMI; International CB; RoHS
- ✓ Passes UL and IK07 Ball Drop tests
- ✓ 50,000 hour demonstrated MTBF
- ✓ 3-year standard global warranty



New sleek finished enclosure

Model	Diagonal size	Aspect ratio	Contrast ratio	Brightness (panel)	Viewing angle	Native resolution
1093L	10.1"	16:10	800:1	350 nits	85°/85° or 170°/170°	1280 x 800 at 60Hz
1291L	12.1"	4:3	1500:1	450 nits	89°/89° or 178°/178°	800 X 600 at 60Hz
1590L	15"	4:3	800:1	300 nits	80°/70°- 80° or 160°/150°	1024 X 768 at 60Hz
1593L	15.6"	16:9	500:1	300 nits	80°/80° or 160°/160°	1366 x 768 at 60Hz
1790L	17"	5:4	1000:1	250 nits	85 °/80° or 170°/160°	1280 x 1024 at 60Hz
1990L	19"	5:4	1000:1	250 nits	85°/80° or 170°/160°	1280 x 1024 at 60Hz
1991L	19"	5:4	1000:1	250 nits	89°/89° or 178°/178°	1280 x 1024 at 60Hz
2094L	19.5"	16:9	3000:1	250 nits	89°/89° or 178°/178°	1920 x 1080 at 50, 60Hz
2293L	21.5"	16:9	1000:1	250 nits	85°/80° or 170°/160°	1920 x 1080 at 50, 60Hz
2294L	21.5"	16:9	1000:1	250 nits	89°/89° or 178°/178	1920 x 1080 at 50, 60Hz
2494L	23.8"	16:9	3000:1	250 nits	89°/89° or 178°/178	1920 x 1080 at 50, 60Hz
2794L	27"	16:9	3000:1	300 nits	89°/89° or 178°/178	1920 x 1080 at 50, 60Hz

10" to 27" desktop touchmonitors, All-in-Ones and interactive digital signage from 10" to 70"

SUZHAPP also distributes the complete line of Elo Touch Solution products — seen in cashier cages, sports betting outlets, and on the gaming floors in top casinos around the world. Monitors and All-in-Ones for front/back office, interactive digital signage, bingo, lottery, sport betting, player tracking, loyalty systems and POS.



SH1950 Video Topper

19.5" high viewing angle panel with LED back light

The SH1950 Video Topper consists of a 19.5" wide viewing angle panel with LED back light, VGA or DVI cable out, 12V input and can be equipped with a black or chrome bezel. The sides have RGB illumination covered by an acrylic front plate. The SH1950 Video Topper and Edge Lit Topper are manufactured in SUZOHAPP China, in accordance to the highest standards. Final assembly, as well as customizations are done at a regional production facility.

The SH1950 Video Topper is a great addition to every cabinet!

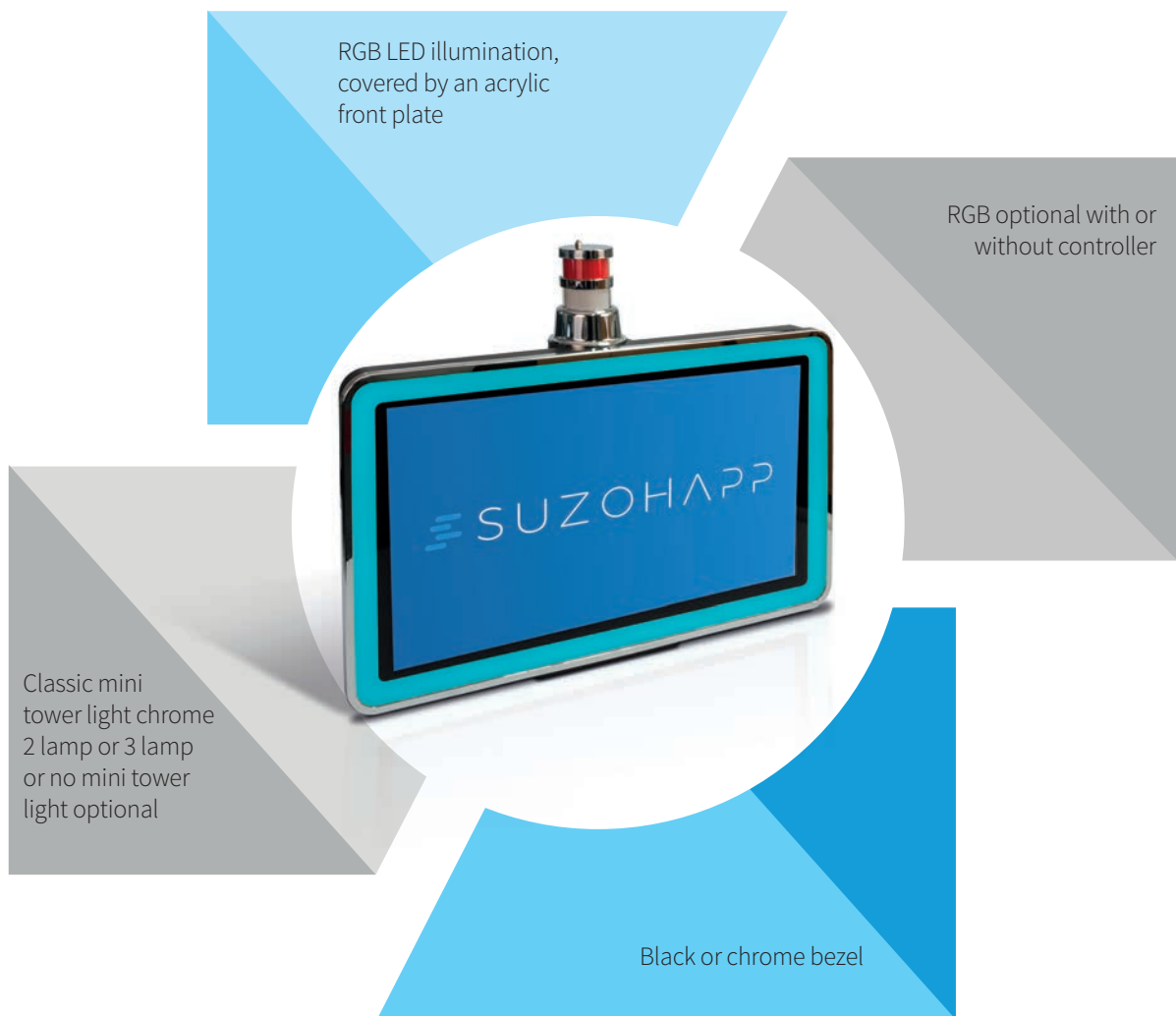

19.5" high viewing angle panel with LED back light (optional without LCD to be used as a light box)

RGB Mini Topper



- ✓ Whole unit operates on a safe 12Vdc
- ✓ Different attract modes in a program such as twinkling, full on, rotating left to right and right to left, filling rotation etc
- ✓ Standard supplied with 32 bright white LEDs (7 different light brightness selections on the topper control board)
- ✓ Standard supplied with bright chrome bezel
- ✓ Mounting location and through holes for tower lights in the top of the body
- ✓ Flat, angled or radius base options for different cabinet configurations, easy mounting with two threaded studs
- ✓ Metal mounting bracket available for mounting on existing tower light fitting holes, to be used in conjunction with mounting bracket

RGB Polygon Topper



- ✓ Completely backlit thanks to bright white LEDs
- ✓ Includes tower light with colour foils
- ✓ On board PCB allows stand-alone operation or synchronization of up to eight topper boxes
- ✓ Seven pre-programmed flashing patterns
- ✓ Different attract modes including full on, rotating left to right and right to left, flashing and more
- ✓ Optional mounting base available
- ✓ Artwork not included

RGB Tower Light Topper Accessories



- ✓ Designed to be mounted on top of any standard round classic tower light
- ✓ Great for advertising special machine features such as Multi-Denomination, Ticket-In Ticket-Out, Hot New Game, Server Based Gaming, etc.
- ✓ Translucent bezel with 20 ultra-bright Nichia multi-colour
- ✓ RGB LED's provide light output for an elegant multi-coloured lightshow
- ✓ Pre-programmed with 8 unique flashing patterns and 7 different colour combinations
- ✓ Several optional base/cap adapters make it easy to use on other styles of tower lights



Ballast



Mounting base - flat



Synchronizer



Compact fluorescent lamp



Power supply



RGB LED light strips



Mounting base - 15° Slant angle



LED light strip controller

Dual-Sided LCDs Interior Signage

Perfect for casinos, table games, signage or other interior environments

With its stylish design the Dual-Sided LCDs displays are a slick way to share content, catching customers coming and going. Available in three distinct sizes to insure the perfect fit for your venue. The low power requirements allow the display to stand out just about anywhere. To eliminate dual graphic and multiple PC issues both displays are driven by a single HDMI signal source.

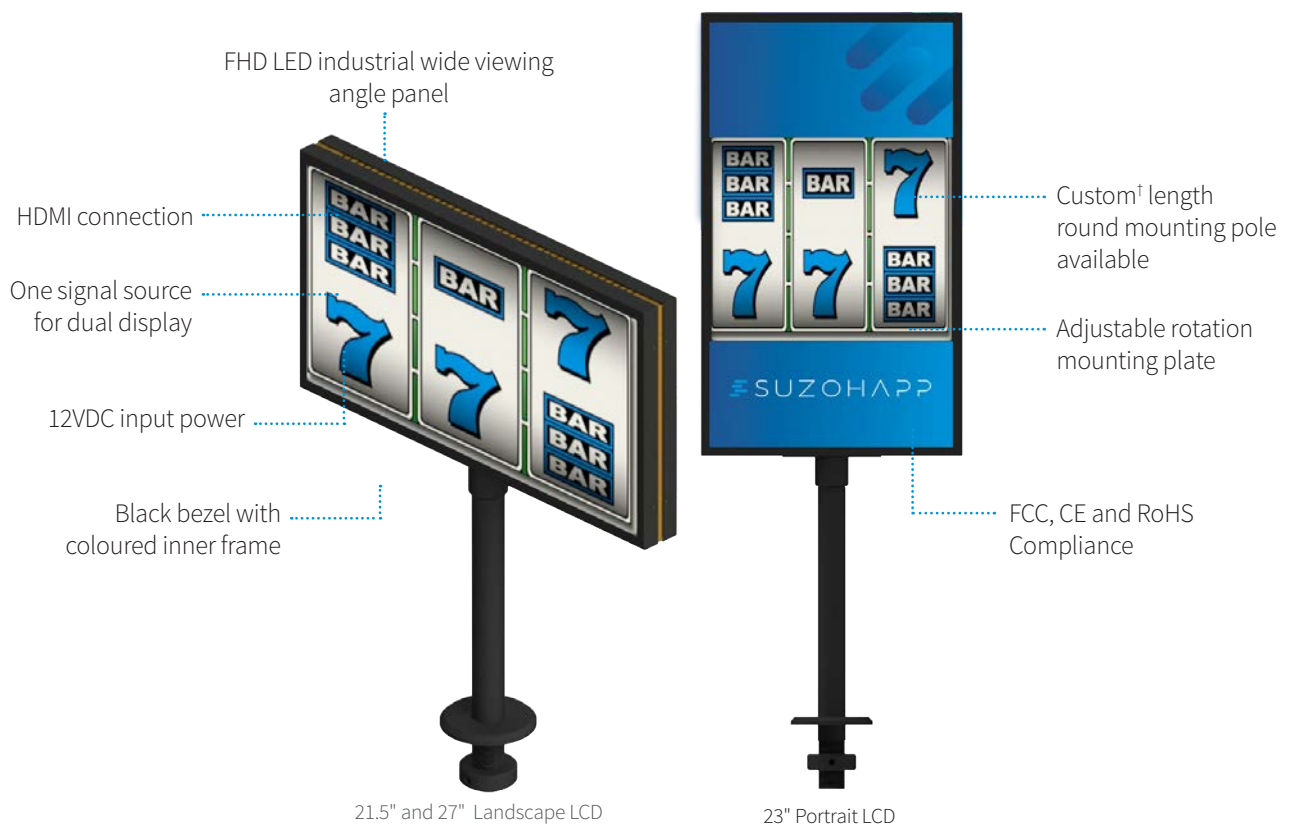

1 M[†] round pole with black bezel with added gold* edge featured

*Different outer and inner colour available upon request but MOQ's apply.

[†] Custom pole length and base mounting options available upon request but MOQ's apply.

Technical Specifications

Screen Diagonal	21.5"	23"	27"
Orientation	Landscape	Portrait	Landscape
Resolution	FHD 1920 x 1080	FHD 1920 x 1080	FHD 1920 x 1080
Panel Brightness	250 cd/m2	250 cd/m2	250 cd/m2
Contrast Ratio	3000:1	1000:1	1000:1
Operating Temperature	0 ÷ 50 °C	0 ÷ 50 °C	0 ÷ 50 °C
Viewing Angle	89° all sides	89° all sides	89° all sides
Power Requirements	12vDC	12vDC	12vDC
Display Height	Custom [†]	Custom [†]	Custom [†]

Dynamic Panel Systems

SUZOHAPP's Dynamic Panel Systems (DPS) feature the latest innovation in pushbuttons - all the adaptability of touchscreens with the tactile satisfaction of mechanical pushbuttons. We remove the limits of standard LCD pushbuttons in both shape and content, utilizing a single LCD with a unique fibre optic conduit to elevate the image to the surface of the injection moulded plastic lens cap. Easily program the entire deck at once with dynamic and configurable content allowing for unprecedented interaction between games and buttons as well as ease of transition between content.



Self-labeling buttons without the complexity or cost

Touchscreen flexibility, with familiar tactile feel

Optional illuminated RGB bezel

Confidence and speed of a physical button

Excellent visibility without glare or distortion

Interfaces: VGA, DVI-D or LVDS

Button interface is available in RS232 or USB

DisplayPort and HDMI are available upon request

Advantages

- ✓ Incredibly flexible – the display panel and buttons can be virtually any size to fit your cabinet and the buttons can be manufactured in any shape
- ✓ Innovative use of precision image transfer fibre optics
- ✓ Traditional tactile pushbutton feel
- ✓ Display graphics, text, animations, video, and even highlight error states with moving colour
- ✓ Add versatility and intrigue to games to attract attention

LCD Pushbuttons

The LCD Button unit is an innovative addition to the SUZOHAPP range for gaming devices, giving the game designer the additional tools to enhance the content and player of new gaming machine concepts.



LCD is integrated into the button and moves with lens cap

Light ring comes in a range of colours

Option to customize LCD decal surround (black standard)

24 frames per second animation

Full colour 128 x 128 pixels

USB interface, controller board controls up to 16 buttons

Chrome-Luminescent Pushbuttons

Polished chrome-plated button bezel with translucent colour washer moulded in bezel to provide edge luminescent effect. Available in several colour combinations of button & luminescent effect. Additional customization also available.



- Locking nut has special design to allow it to fit over “Snap-Tab” feature with microswitch installed
- Ease & flexibility of mounting to metal control panels using either the “Snap-Tab” or traditional locking nut
- Switch pre-assembled on button for reduced assembly time into control panel
- Subminiature microswitch provides additional clearance room under control panel
- Grounded for ESD protection
- Polycarbonate lens for optical clarity and durability
- Switch snaps on bezel of button eliminating the need to have separate lamp holder

STC Pushbuttons

STC Pushbuttons with Subminiature Microswitch designed to retrofit all existing VLT/Poker buttons which use a 22 mm square mounting hole. Available in 6 different colours: red, orange, yellow, green, blue or white.



- Designed to resist spills and sticking, for high reliability and long life, tested for 10 million+ cycles
- Standard supplied with spacer bezel for mounting on top or in the panel (low-profile)
- Small size, low profile, provides maximum player comfort
- Full 0.5 mm thickness on lamp terminals holds lamp or LED connectors securely
- For use with 5 mm wedge base lamps or LEDs (not included)
- Standard fitted with Cherry DB5 style microswitch with 2.8 mm terminals for easy connection

Jumbo White Pushbuttons with Black Trim

RGB LED, UFO Style

Features

- ✓ Achieves magnificent lighting effects
- ✓ 13 different display modes to control.
Enhance user interaction for your machine
- ✓ Top quality with a competitive price
- ✓ Simple installation takes your machine assembly to the next level
- ✓ Available in different colours



LCD Button Decks

15" 1/3 LCD Button Deck

- ✓ 10-point PCAP
- ✓ 170°/160° viewing angle
- ✓ 2T glass
- ✓ Black masking
- ✓ R5 corners
- ✓ USB



16.4" LCD Button Deck

- ✓ 170°/160° viewing angle
- ✓ 10-point PCAP
- ✓ 2T glass
- ✓ Black masking
- ✓ USB



16.4" LCD Button Deck with customized glass

- ✓ 170°/160° viewing angle
- ✓ 10-point PCAP
- ✓ 2T glass
- ✓ Black masking
- ✓ USB
- ✓ 1 push button hole



Coin Entries

For application on flat surfaces and with various inclinations

Devices in different colours and sizes. Some models are equipped with lighting to attract more attention.



Standard coin entry for flat surfaces. Available in chrome or gold finish, with coin reject lever



Adjoining coin entry flat surfaces. Available in chrome or gold, with coin reject lever



Coin entry for flat surfaces. Available in black ABS, with coin reject button, in the lengths of 7-20-30 and 45 mm



Top coin entry for flat surfaces. Available in chrome plated steel, with coin reject button



Coin entry for surfaces with a 30° inclination. Available in chrome or gold finish, with coin reject lever



Coin entry for surfaces with a 30° inclination. Available in black, chrome or gold finish, with a coin reject button and in lengths of 42.5 – 62.8 mm



Coin entry for surfaces with a 30° inclination. Made of die-cast material with a coin reject button and in lengths of 42.5 – 62.8 mm



Standard coin entry for inclined surfaces. Solid and robust, it is made of chrome plated steel, with coin reject button. It accepts coins up to 3 mm thick



Cast metal coin entry for surfaces with a 15° inclination. Characterized by its sharp lines and catchy design



Coin entry for surfaces with a 30° inclination. It is available in chrome plated steel, with a coin reject button and luminous "COIN" inscription

RM5 HD

Extreme reliability, remarkable acceptance speed and high versatility

The RM5 HD coin validator has set new reference standards in coin validation. Through 5 different sensors and 10 recognition parameters, it ensures a high level of recognition and discrimination of valid and counterfeit coins with an unprecedented speed of up to 6 coins per second.



HD high-discrimination system based on 10 different parameters regarding frequency, dimensions and phase

5-sensor identification technology: 3 inductive sensors, 1 optical sensor and 1 magnetic sensor

USB version also available

Advanced electronic and mechanical anti-fraud system: electronic anti-fishing device, coin movement direction detection, 3 mechanical traps, and wire cutting blade

Tropicalised version also available for environments affected by adverse weather conditions

over 2 million Comestero coin mechanisms installed!

RM5 Evolution

The record-breaking coin validator

The RM5 Evolution coin validator is well known for its quality and reliability. Its electronics combines extraordinary selectivity with extreme programming versatility: the Cloning system allows the transfer of the configuration parameters.



3 pairs of inductive sensors for processing 6 different parameters regarding the material and the mass

3 pairs of optical sensors for determining the coin's diameter

Identification channels: up to 59, each of which can be redirected to the outlets. The first 6 support Self-Prog mode

A mechanical and electronic anti-fishing device

Serial interface for external connections (portable programmer or PC)

Credit recognition: parallel, binary, pulse

Coin Sorters

CINCO

Coin sorter with 5 sorting paths plus reject mechanism specifically designed to satisfy the requirements of any type of gaming machine. It can be installed both on machines operating in ccTalk and in parallel, allowing switching modes with ease.



SPS41LCC4

Coin sorter with 4 in-line sorting paths and reject placed over the third sorting outlet.

SPS31LCC3

Coin sorter with 3 in-line sorting paths and reject placed over the third sorting outlet.



SPS31SCC3

Coin sorter with 3 in-line sorting paths and reject placed over the last sorting outlet.

SPS300CC3/VER-B

Coin sorter with 3 in-line sorting paths and a bottom reject mechanism.



SPS300CC3

Coin sorter with 3 in-line sorting ways and front reject.

Cube Hopper

High speed single denomination hopper

The Cube Hopper has an expandable hopper capacity and is made from extremely strong, wear-resistant plastics. With one configuration it covers different coin sizes, and in case of conversion the disc can be replaced in seconds to convert the denomination of the hopper. The hopper is square and easy to mount by means of standard mounting bracket. By using a unique “Sun & Planet” gearbox system, this hopper offers the possibility to contain and count (with two extensions) over 1,200 coins of \varnothing 24 mm. The hopper is protected by an auto-reverse anti-jam system and has an indirect optical readout with a continuous monitored optic sensor control. A low-level detection is integrated in the coin cup. A Dual Hopper version is also available which can pay-out two different types of coins.



Excel Hopper

Extremely durable and the most service-friendly casino hopper

Its gearbox system design provides advantages such as maximum torque with minimum power consumption, unique bayonet motor connection for easy motor replacement, and an easily-accessible coin exit. Available with 3 different bowls: standard bowl, wide or narrow bowl and extended bowl.

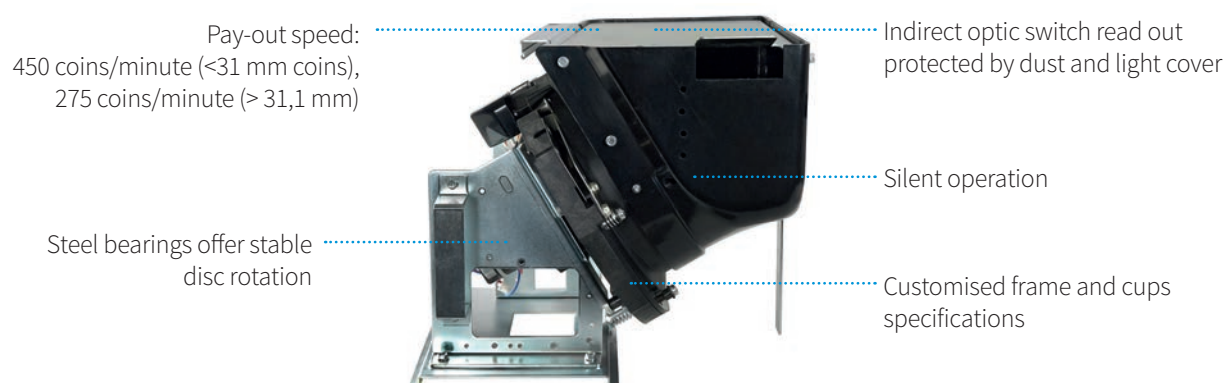

Evolution Hopper

High dispensing speed and reliability come together

Based on a belt drive, Evolution Hopper is excellent in terms of both performance and ease of maintenance. The unique concept provides a single build type hopper that is suitable for 95% of the world's coins and tokens without needing adjustments. A large DC motor in combination with an electronic motor control board yields reduced friction and motor noise. The optic board is easily accessible by removing the electronic control board from outside the hopper.

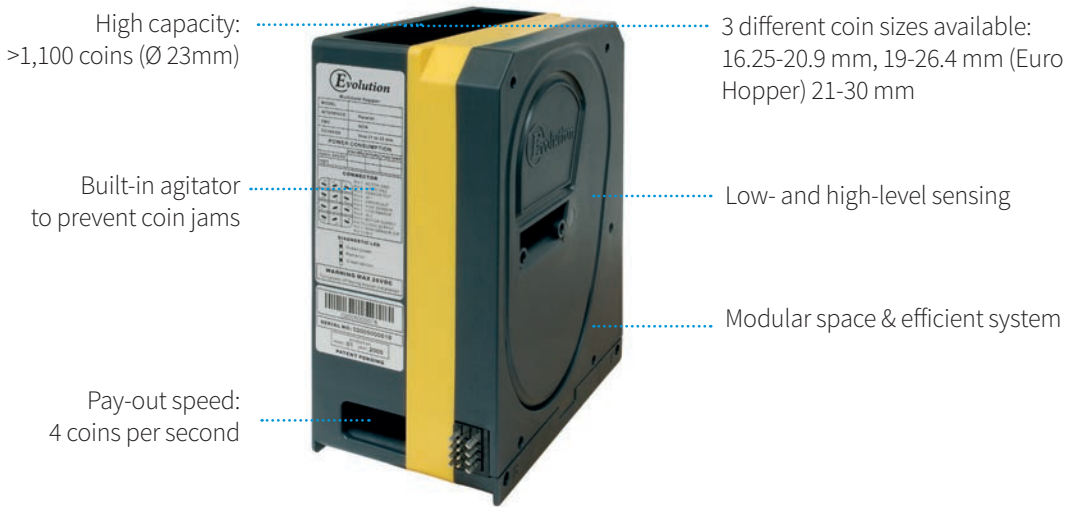

Flow Hopper

Innovative through-hole hopper

The innovative electronics and high-resistance plastic materials ensure durability over time. Available in two interfaces – standard parallel and ccTalk serial. Supplied with quick-release plate.



3 DIFFERENT COIN BOWL SIZES



ICS (Intelligent Coin System)

The innovative coin handling device

The ICS is a revolutionary coin handling device able to process up to 8 different size coins without the need of pre-sorting the coins by the user. Due to its compact design and spacious size (up to 1,300 various sized coins), it is ideal for many applications, and supports a minimum coin-in to coin-out height solution. Thanks to its patented design and SUZOHAPP's long-standing experience in coin handling, this device is the world's first currency solution able to be integrated into machines from diverse markets including parking ticket machines, self-checkout stations, money changers, kiosks and vending. ICS's intelligent interface gives you the possibility to directly manage the pay-out composition or make the calculation itself as to the amount of coins per type to be supplied based on the denomination it holds. It is also able to dispense 4 coins simultaneously.

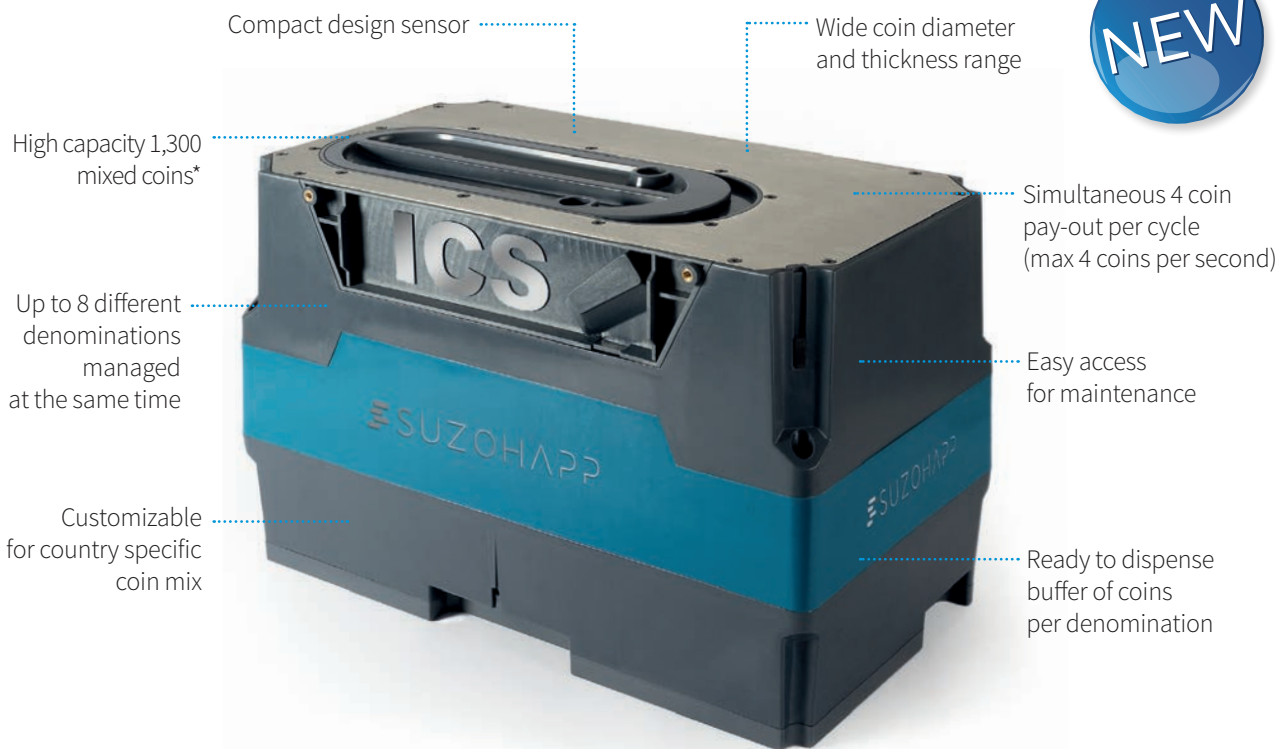

* value can change according to currency

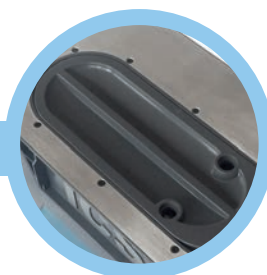

Compact design:
one product that works as 8 hoppers + 1 sorter



High pay-out speed and safety:
it guarantees the correct pay-out per coins' denominations

MFL®

Industry's most reliable, secure, modular design

MFL® is the first ever front load banknote validator designed for automated cash transaction applications. MFL® provides modularity and high security due to unique multi-sensor technology. MFL® utilizes a patented alignment mechanism enabling a high acceptance rate for banknotes and barcode vouchers. Due to its robust design and higher reliability, MFL® lowers total cost of ownership, enhances protection against counterfeits and improves machine uptime.

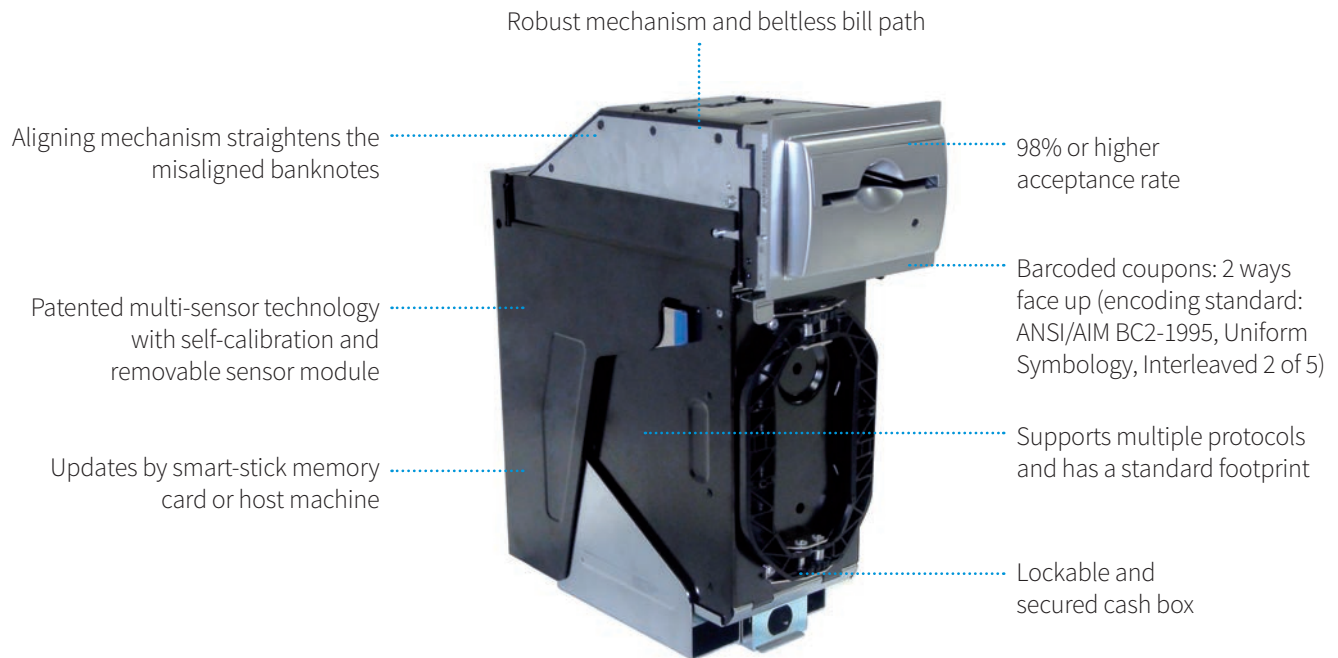

SC Advance™

Featuring enhanced recognition technology, faster note-to-note speed, and improved barcode recognition, the SC Advance™ offers a variety of cashbox options to ensure best fit. It offers a lower cost of ownership with its reliable, field proven technology. Low jam rates and exceptional performance create more machine up-time resulting in higher revenue and increased user satisfaction.



Sealed banknote path protects validator head from fluid and dust significantly reducing the risk of jams

High note acceptance at 98%+ on the first insertion

Flexible design offers a variety of options for bezels, cashbox capacity and note widths

Advance acceptance and security contributes to higher overall acceptance for legal banknotes while increasing security against fraudulent banknotes

Traffic light LEDs provide front-line at machine diagnostics

Several cashbox sizes provide the flexibility you need

4 CASHBOX SIZE OPTIONS



SC 600 notes SCM 900 notes SCL 1200 notes SCXL 2200 notes

Easitrax

Easitrax Soft Count offers a faster, more efficient way to validate revenue, manage cash drops and monitor the performance of your slot machines, even if they reside at multiple locations. The integrated software/hardware system works by collecting data from your SC Advance™ note acceptors and making that information securely accessible in a single database. Now, Easitrax is available as a portal-based system that allows operators to create customized reports and track performance remotely.



NV9 USB+

Enhanced sensing technology

The NV9 USB+ is the next generation banknote validator, boasting enhanced sensing technology and a high acceptance rate for multi-currency. NV9 USB+ is a versatile banknote validator with cashbox and bezel options to suit all applications. The unit can be mounted horizontally or vertically, and exceptional field reliability make the NV9 USB+ a truly global product. A note float module can be added to provide note recycling capability.

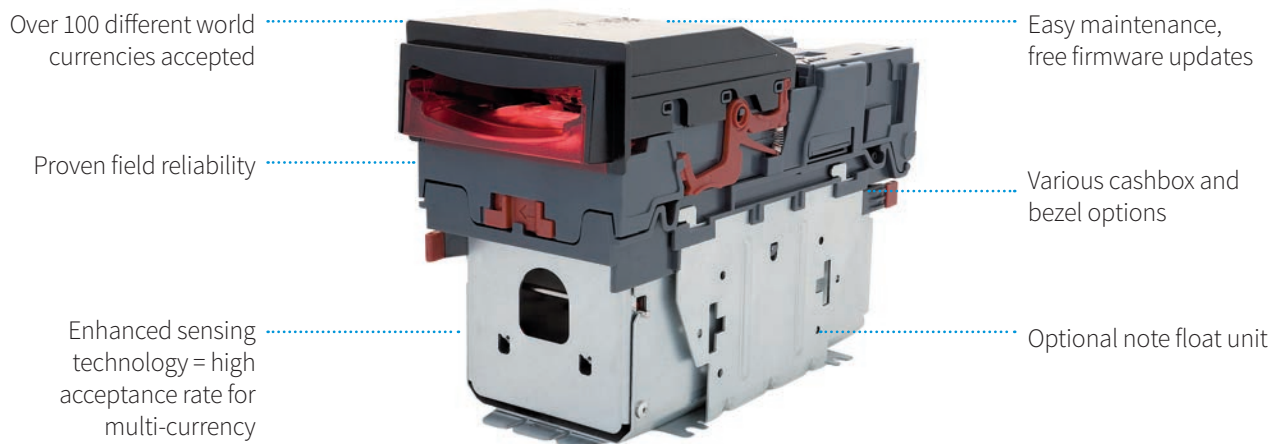

NV10 USB+

Compact stackerless banknote validator

The NV10 USB+ is a compact, stackerless banknote validator suitable for most applications. Accepting over 100 different world currencies the NV10 USB+ is a truly global product. With a field-proven validator, the unit supports industry-standard protocols and is simple to integrate and maintain.

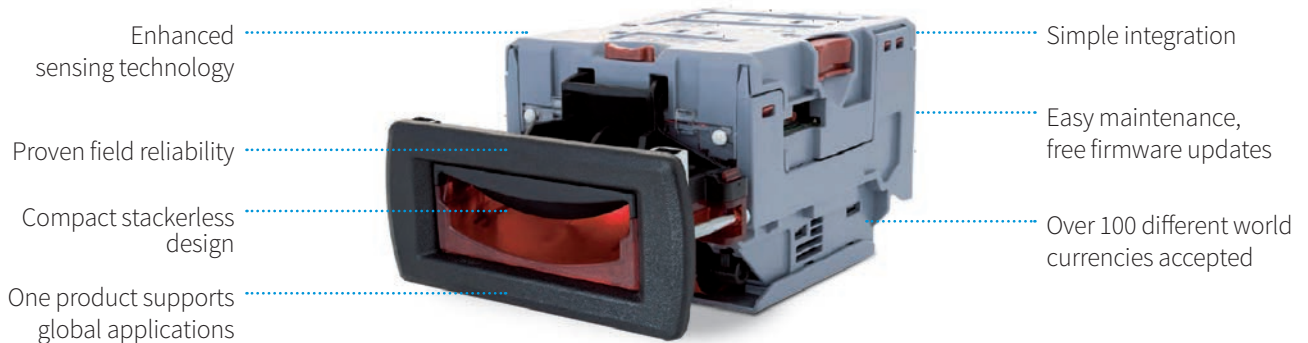

Bill-to-Bill 300™

Advanced sensors technology for Gaming applications

Bill-to-Bill 300™ is the multi-width front load bill recycler with high acceptance rates and superior counterfeit detection due to its patented technology. It is characterized by an advanced sensors technology that improves authentic bill recognition and protects against counterfeits. The validated bills are distributed between three recycling cassettes and one lockable/removable drop cassette. A maximum of 3 denominations may be directed to the recycling cassettes, with the remainder directed to the drop cassette.

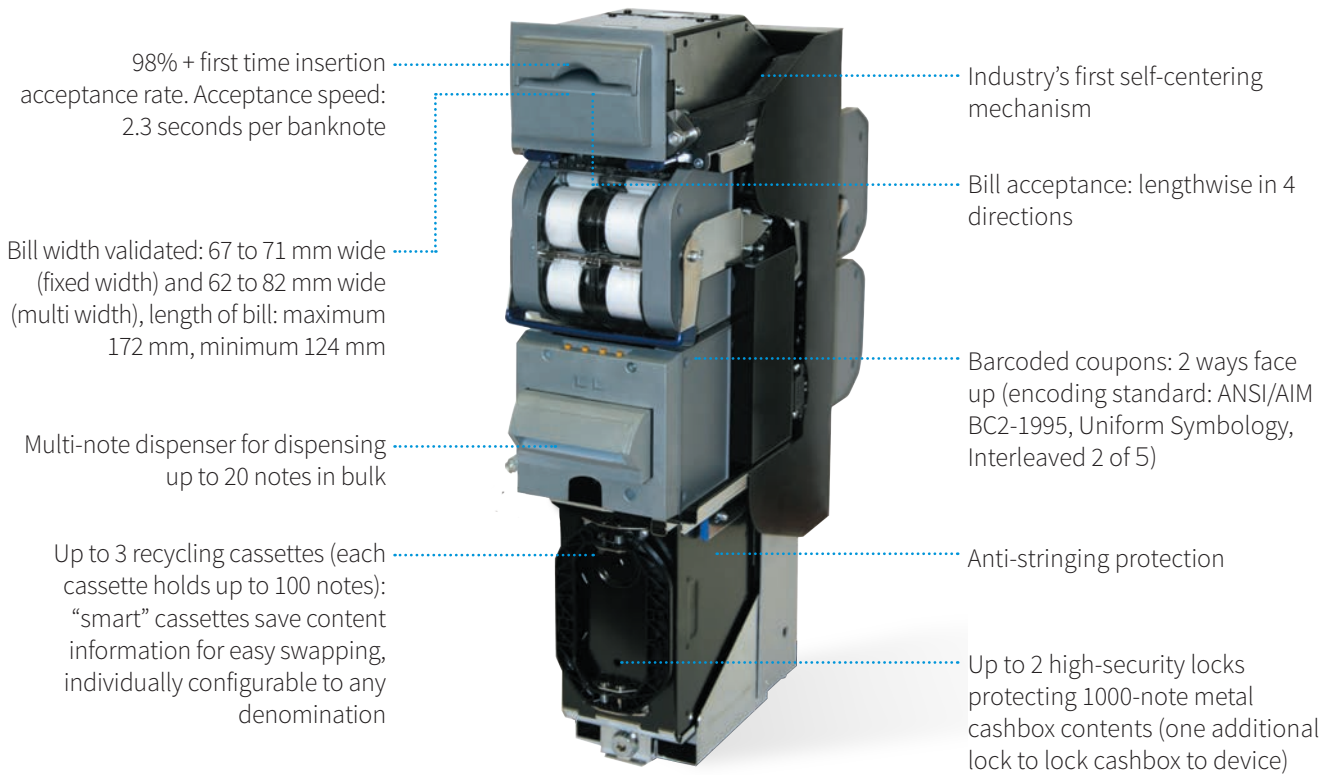

High acceptance rates



Multi-note dispenser



Lockable and removable drop cassette

PayCheck® NextGen™



PayCheck® NextGen™ is the 'One' printer venues need to ensure reliability, functionality and connectivity. It's the fastest printer in gaming.

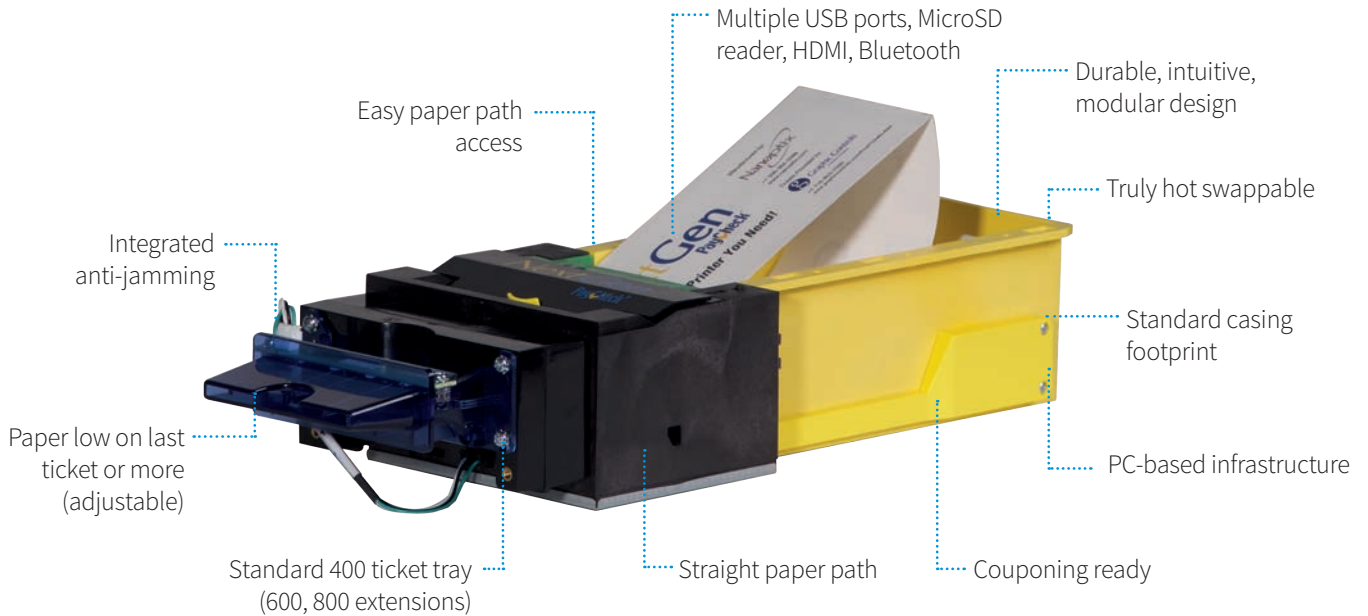

Benefits

- ✓ Better reliability and lower overall cost
- ✓ Greater customer satisfaction
- ✓ Reduces paper jams – no matter the bezel used
- ✓ Save on paper cost by no longer wasting tickets
- ✓ Use any fonts, images and logos for your tickets
- ✓ No jamming within a presenter
- ✓ Fast & easy maintenance
- ✓ Easy field service and upgrades
- ✓ Easy access to all major components
- ✓ Fast plug-and-play replacement without powering down
- ✓ Reduce downtime with larger ticket capacity
- ✓ Usable in all jurisdictions worldwide

Ticket tray note size



Multiple bezel options

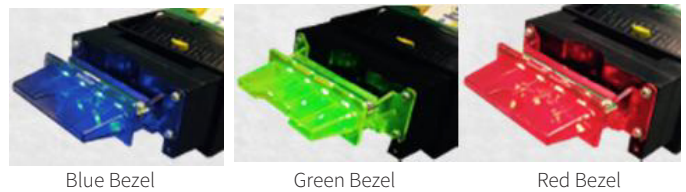

Integrated anti-jamming paper path



Easy access for simplified maintenance

PayCheck® 4™



Only the PayCheck® 4™ Thermal Printer can print a ticket in just 0.6 seconds! In fact, the PayCheck® 4™ is so lightning fast, there's no need to rely on a "burst", like some other, lesser printers do. Also, the PayCheck® 4's 8 MB of standard memory enables you to store more fonts, images, logos and barcodes, so you can personalize your players' gaming experience. With a lifespan of approximately 640,000 TITO tickets, its print head has the longest life of any in gaming.

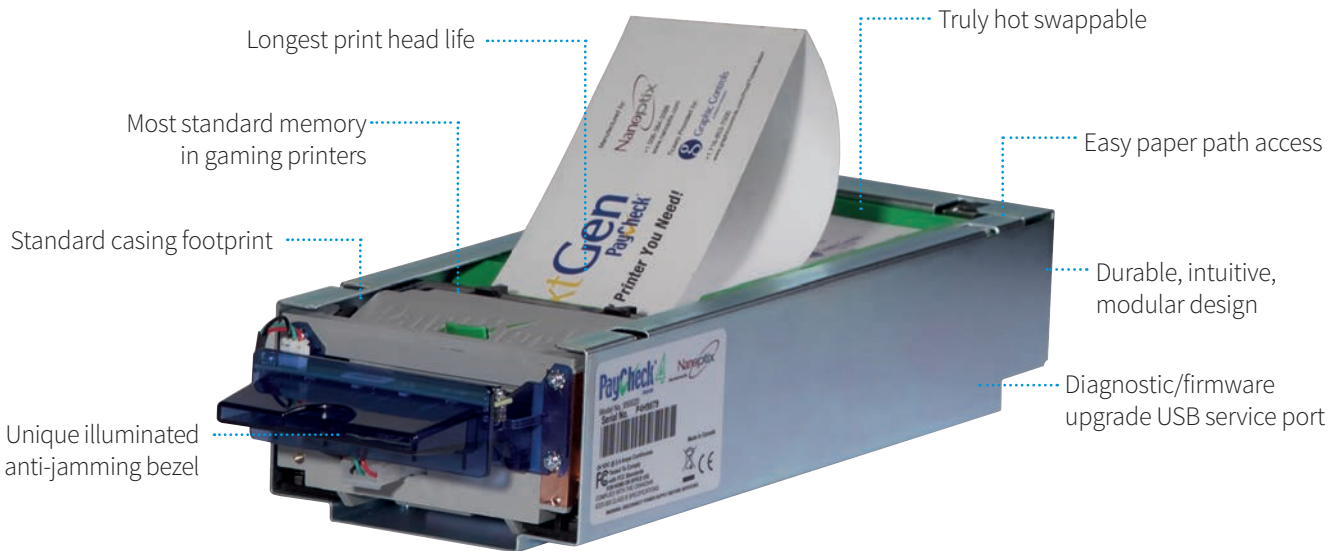

Benefits

- ✓ Greater customer satisfaction
- ✓ Better reliability and lower overall cost
- ✓ Let you personalize with fonts, images and logos
- ✓ Fast plug-and-play replacement without powering down
- ✓ Reduces paper jams for more uptime
- ✓ Fast & easy maintenance
- ✓ Easy access to all major components
- ✓ Easy field service and upgrades
- ✓ Usable in all jurisdictions worldwide

Ticket tray note size

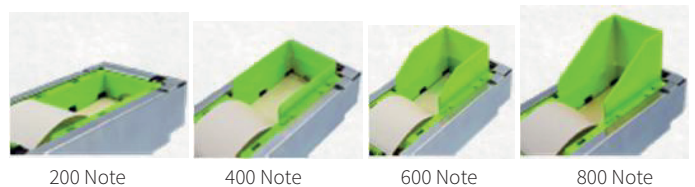

Multiple bezel options



PayCheck® Terminal™



PayCheck® Terminal™ is the world's first Kiosk terminal powered by a TITO printer. Taking advantage of the power and uniqueness of the PayCheck® NextGen™ printer, we created a Linux-based terminal for your gaming, lottery and retail applications.



Benefits

- ✓ Variety of applications:
 - Validation terminal station
 - Bill to TITO printout kiosk
 - Payment kiosk
 - Players loyalty kiosk
 - PullTab kiosk
 - Self-Serve lottery terminal
 - Promotional kiosk
- ✓ SDK compatible with your GMS provider and/or marketing promotional provider
- ✓ deal for desktop or self-server application
- ✓ Maximizing space with its small footprint
- ✓ Networkable
- ✓ Advertise your services easily
- ✓ Reduce downtime with large ticket capacity



Secure PIN Entry Module



Paycheck® Kiosk™ with Bill Validator

HSV L Advanced™

HSV L Advanced™

The HSV L Advanced™ (High Speed Video Lottery) printer provides manufacturers ultimate flexibility and outstanding reliability. By using innovatively-designed movable spindle arms the HSV L Advanced can adapt to any kiosk design.

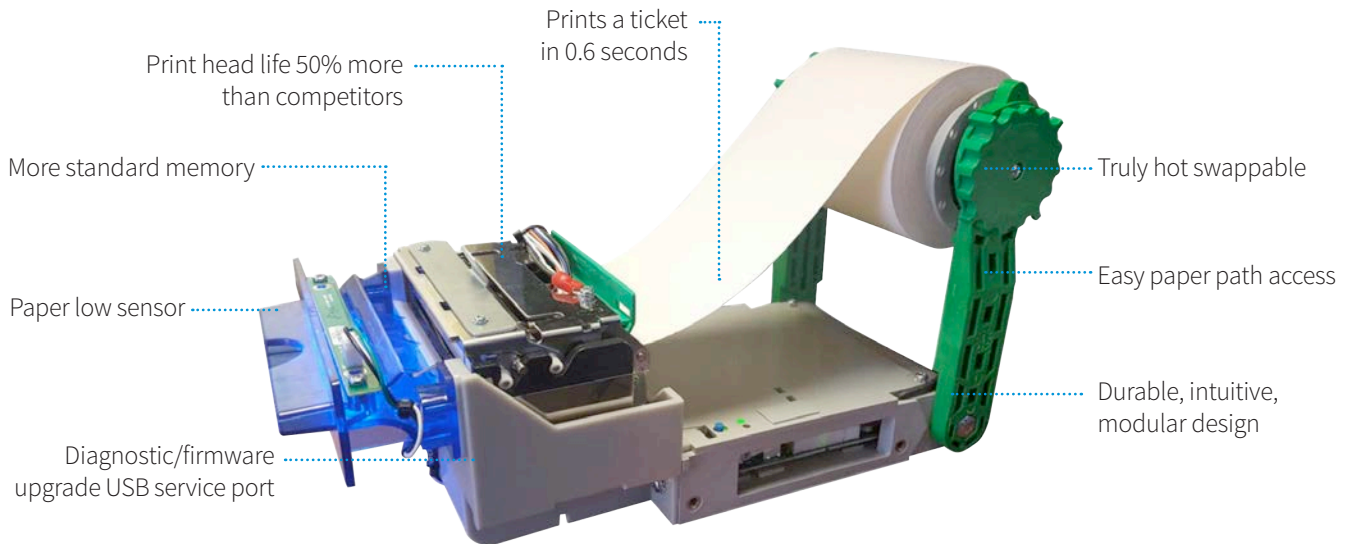

Benefits

- ✓ Greater customer satisfaction
- ✓ Better reliability and lower overall cost
- ✓ Let you personalize with fonts, images and logos
- ✓ Able to replace paper with little or no down time
- ✓ Reduces paper jams for more uptime
- ✓ Easy replacement without powering down
- ✓ Fast & easy maintenance
- ✓ Easy access to all major components
- ✓ Easy field service and upgrades
- ✓ Usable in all jurisdictions worldwide

Configurable options

- ✓ Horizontal
- ✓ Vertical (with extra bracket)
- ✓ Upside down
- ✓ Board separate

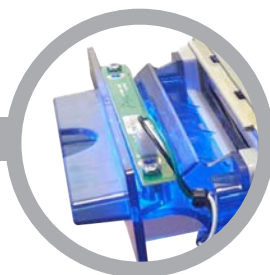
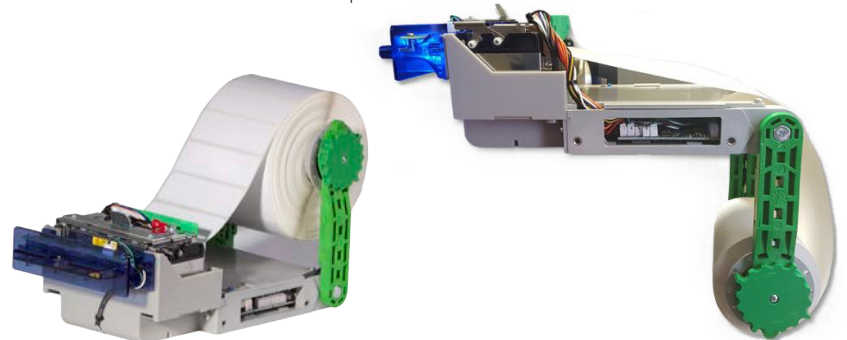

Unique illuminated jamming resistant bezel



Upside down (with extra bracket)

EZ-Tear™

EZ-Tear™

The EZ-Tear™ printer provides manufacturers flexibility while remaining compact and reliable. Built with modularity in mind, the EZ-Tear™ printer will fit many types of cabinets and with its clamshell design, provide easy access for paper loading.

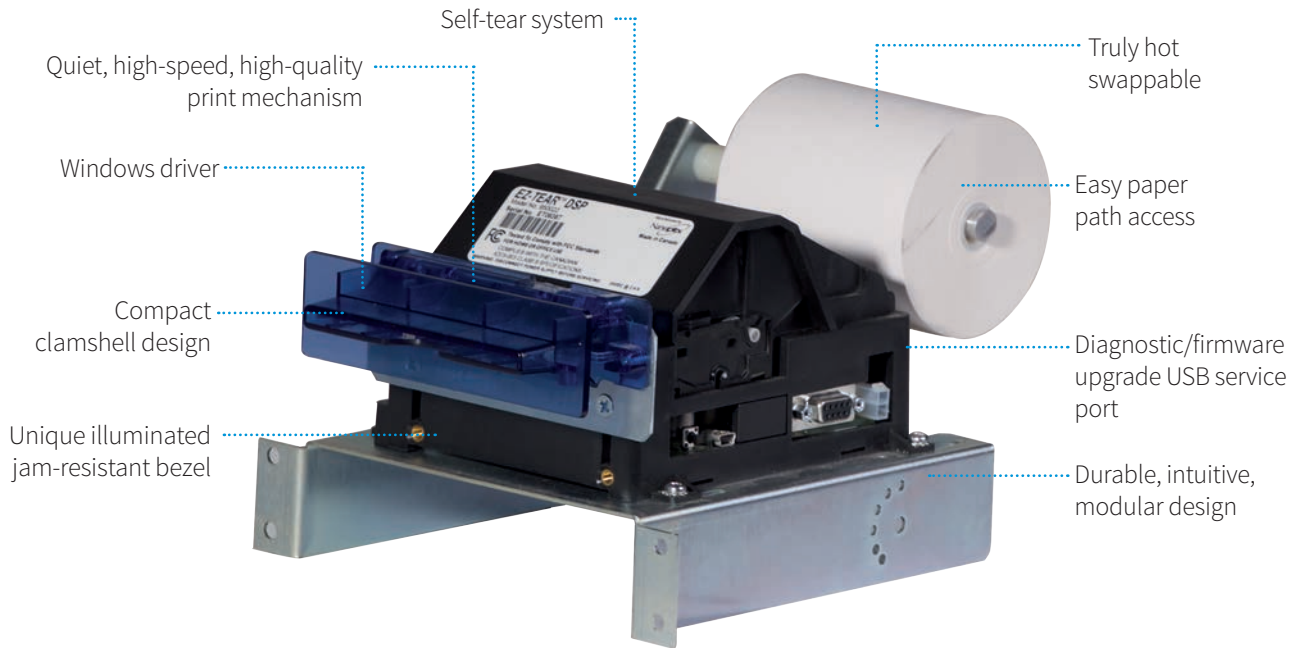

Benefits

- ✓ Lower cost of ownership
- ✓ Better reliability & customer satisfaction
- ✓ Print directly from any Windows O/S
- ✓ Provides easy paper loading
- ✓ Reduces paper jams for more uptime
- ✓ Easy replacement without powering down
- ✓ Fast & easy maintenance
- ✓ Easy access to all major components
- ✓ Easy field service and upgrades
- ✓ Usable in all jurisdictions worldwide

Configurable options

- ✓ 65 mm or 80 mm
- ✓ Compact
- ✓ Compact + Bezel
- ✓ Base Plate + Spindle
- ✓ Base Plate + Spindle + Bezel

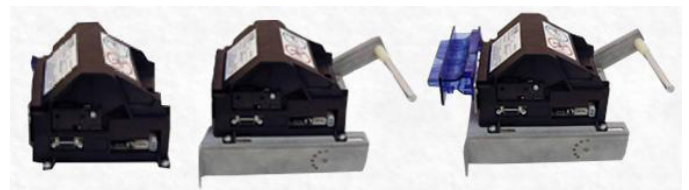

Modular design

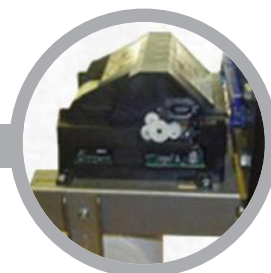



PayCheck® High Speed Couponing™

Specifically designed for printing promotional coupons, it prints a ticket in 1.2 seconds.

Barcodes: interleaved 2 of 5, Code 39, Code 93, UPC-A & UCP-E, CODABAR, EAN 8 & EAN 13, CODE 128

Print in sequence

64 Mbit SDRAM, 16 Mbit flash for storing code, fonts, logos, images etc.

Print head life of 100 km

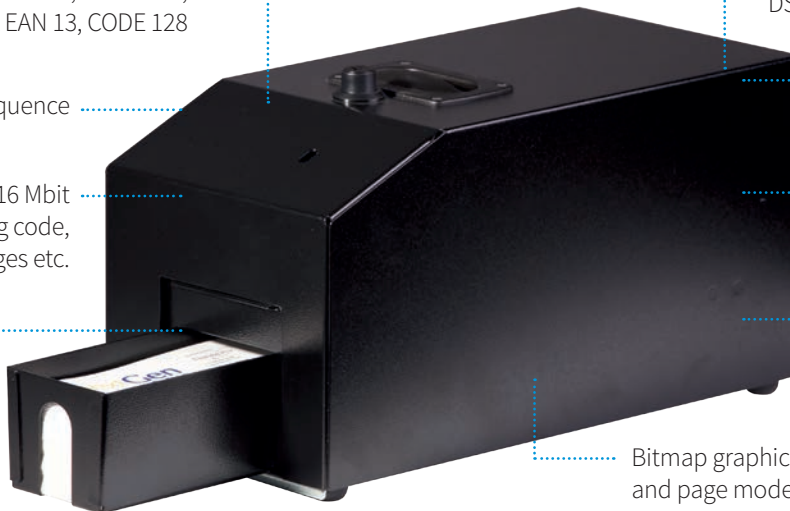

Real-time operating system, DSP/BIOS

Many protocols and emulation available

Host-controllable buzzer/alarm and status indicator lights

Multiple sensor: top of form, ticket in, ticket out, ticket low

Bitmap graphics: portrait, landscape and page mode printing

Benefits

- ✓ Easy to use configuration & diagnostic tools
- ✓ Downloadable firmware
- ✓ Supports multiple fonts and barcodes
- ✓ Rugged, intuitive design for durability and ease of use
- ✓ Power-up self-test

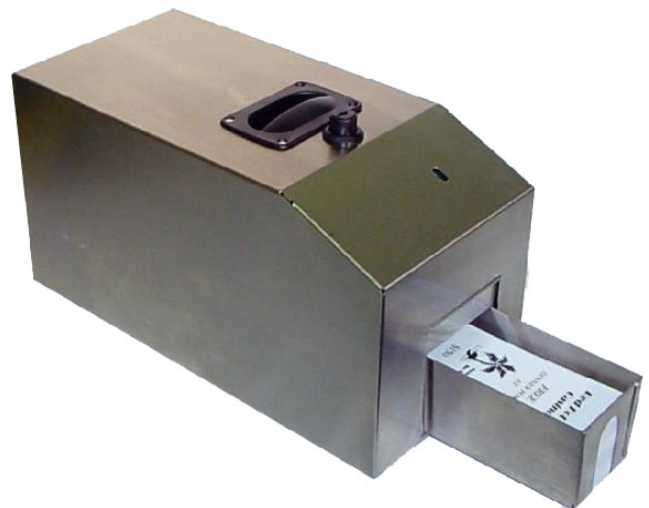

Lockable cover and rugged metal design



Automatically cuts and stacks 200 promotional tickets

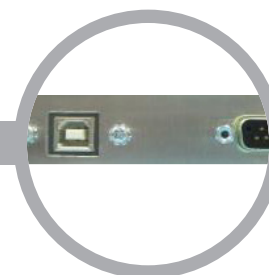

USB and serial port

“Spill-Proof” Thermal Printer

It’s fast, quiet, efficient, affordable and easy to use. Best of all, its patent-pending spill-proof design means never having to worry about OOOPS again. IEC60529, IPX3 spillage approved.



“Spill-Proof Cuts” Printer

“Spill-Proof Cuts” protects your printer from potentially costly liquid spills and it also quickly and efficiently “cuts” the paper for maximum ease of use.

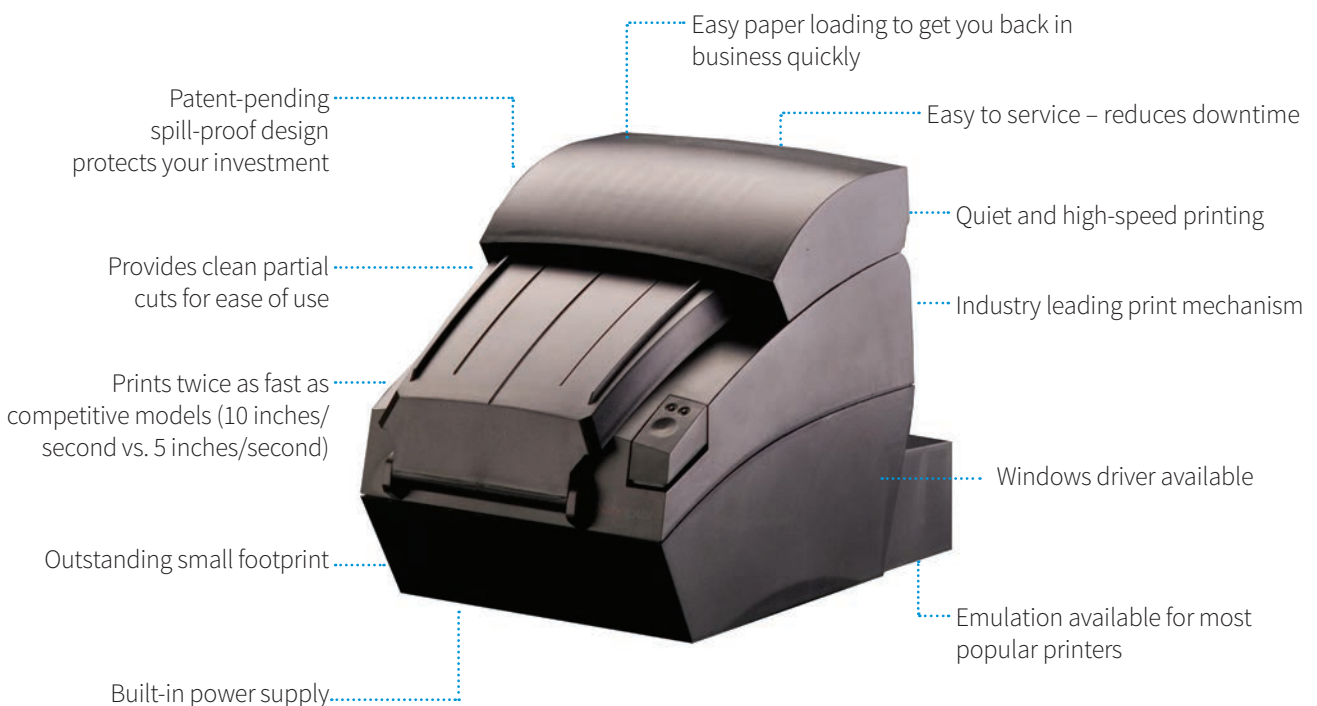

Slot Machines Tickets

Superior quality slot machine tickets, from blank stock tickets to customized tickets with 4-way repeat backside print. Tickets are approved for use in International Game Technology's (IGT) EZ-Pay™ and Sierra Design Group's (SDG) voucher systems.



Unlimited colour possibilities and 4-colour printing processes provide photo realistic quality and colour reproduction



Digital proofing systems guarantees the best match to press



Reliable and flexible security options protect against fraud



On-the-spot authenticity verification with thermochromic, blacklight visible UV and coin-reactive inks



Customized Tickets

Possibility to have 4 different designs on the backside of the ticket, this is a so-called 4-way repeat print, where you can choose any 4 designs which will be repeated every 4 tickets.

This is especially interesting to promote special offers from restaurants or specific games.

Barcode Scanners



1 FM100

Features

Ease of integration
Designed for OEM applications, this high performance fixed CCD scan engine can easily be integrated into various solutions such as kiosks, ticketing machines, (Reverse) Vending Machines and many more. The small form factor enables easy integration into various solutions. The FM100 has an IP54 rating meaning it is dust- and water resistant.

Advanced technology
Includes core-technology UIMG, which is independently designed and manufactured by Newland Auto-ID. UIMG technology includes the optical, CMOS, digitizer, decoder, image processing & embedded systems. The scanner supports all global standard 1D symbologies. Its reading performance reaches and exceeds global standards. By using the accessories provided, the user can ideally set up the scanner to its user environment.

2 FM430 Barracuda

Features

Megapixel camera
The FM430 Barracuda is a barcode scanning powerhouse. No matter what type of barcode is presented, the megapixel camera allows users to scan 1D and 2D barcodes, including very small ones, with impressive speed and ease.

Snappy, also in less than perfect conditions
A combination of the IR sensor and the light sensor helps to keep workers moving, even in low light conditions. Its strong, white light ensures barcodes are always well lit.

Handsfree or manual scanning
Companies looking for automatic scanning to relieve manual labor can set up the FM430 Barracuda for handsfree scanning. Alternatively, a manual trigger button can be used if preferred.

Intelligent programming
The sensors of the FM430 Barracuda automatically adjust the brightness of supplementary lighting based on the light that reflects off the barcode. This also makes it an optimal solution for scanning from mobile phone screens. Depending on the application, the scanner can be set to optimally read from close and long distance.

Reliable outdoor use
With an IP rating of 54, this fixed mount scanner can be placed in a housing and used outdoors without worrying about dust or moisture.

Bright laser aimer (optional)
The FM430 Barracuda is available with a red cross laser that makes scanning easy and intuitive, even for the most inexperienced users.

3 FM30 Grouper II Series

Features

Superior decoding performance
Your employees can scan virtually any barcode, including 1D and 2D, at an extraordinary speed.

Effortless scanning from mobile phone screen
Built to read from an LCD screen, the FM30 Grouper II Series can easily read barcodes from any mobile device screen. An extended capability of IR reading allows the device to detect barcodes under virtually any ambient light. Whether you operate at daytime or nighttime, scanning is quick and efficient.

Easily mounted in small spaces
The FM30 Grouper II Series is designed for businesses that require high performance and a minimal footprint. With its small size, the device is ideal for kiosk integration and other POS solutions.

Easy to install
The FM30 Grouper II Series can be set up quickly and easily. A plug-and-play simplicity enhances your experience right from the start. The device can be further configured according to your needs by using a simple barcode programming guide.

4 EM2037-V4

Features

Superior decoding performance
No matter what type of barcode is presented, the megapixel camera allows users to scan 1D and 2D barcodes, including very small ones, with impressive speed and ease. In addition to excellent scanning of high-density barcodes, the EM2037-V4 also provides the added value of decoding postal barcodes.

Advanced technology
The EM2037-V4 is powered by advanced imaging technology and Newland patented UIMG technology, a computerized image recognition system, can read barcodes printed on paper/plastic or displayed on mobile phones with excellent motion tolerance.

Powerful data editing capability
The scan engine allows customizing scanned data with ease and provides supporting software to address diverse application needs.

Compact & lightweight design
Seamless integration of imager and decoder board makes the scan engine very small, lightweight and easy for integration.

Various interfaces
The EM2037-V4 supports USB and TTL interfaces to meet customer needs.

Redemption Tickets and Dispensers

Deltronic Ticket Dispenser

- “Snap out” one ticket dispenser – replace it with another in seconds
- No tools necessary
- Fool proof braking system is easily adjustable
- Validation “Diamond” mark identifies tickets
- Available as Continuous or Pulse type

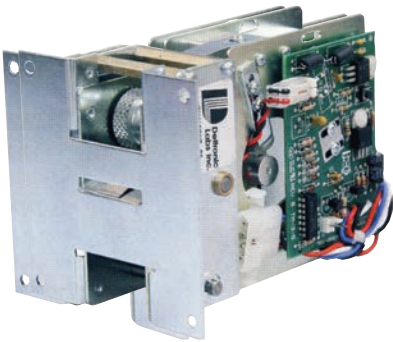

ENTD-2000 Ticket Dispenser

- Virtually eliminate ticket jams
- Requires very little maintenance
- One of the most reliable and compatible ticket dispensers on the market

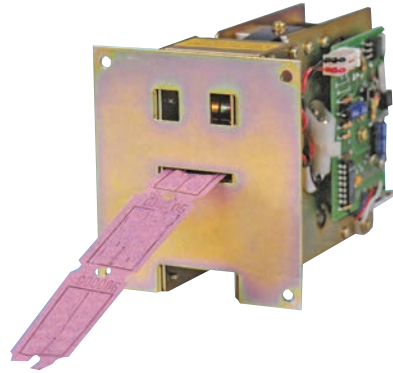

Tickets can be personalized to your requirements

Door Switches

Single and Double Pole

- Choice of push and push-pull interlock switches
- Snap-in panel mounting
- Long-life coil spring, snap-action mechanism
- Temperature rating -40° to +85°
- Flammability rating UL94V-0
- Various approvals available
- Detailed datasheets available



Cooling Fans



DC Cooling Fans

- Compact cooling fans
- Wire connection
- 12 or 24 Vdc
- Speed up to 5800 RPM

AC Cooling Fans

- Protects electronics from overheating
- Easy mounting with 4 bolts
- Terminal or wire connector
- Speed up to 3000 RPM



Finger Guards for Cooling Fans

- Protects electronics from over heating
- Easy mounting with 4 bolts



Charge'N Play

Add USB Charging capabilities to your machines

Charge'N Play is the innovative dual USB charger – easy to install and simple to use, and a magnet for customers. Charges up to 2 electronic devices through the USB port. Charge'N Play can be installed in cabinets or integrated in the wall.

- 2 USB ports
- Top or side mount module
- Optional installation kit
- Designed to mount easily to wood or metal cabinet
- Optional 3-way micro-USB cable (1m length) lighting connector
- Compatible with popular mobile devices



Also available as kit, with cable, wobbler and power supply

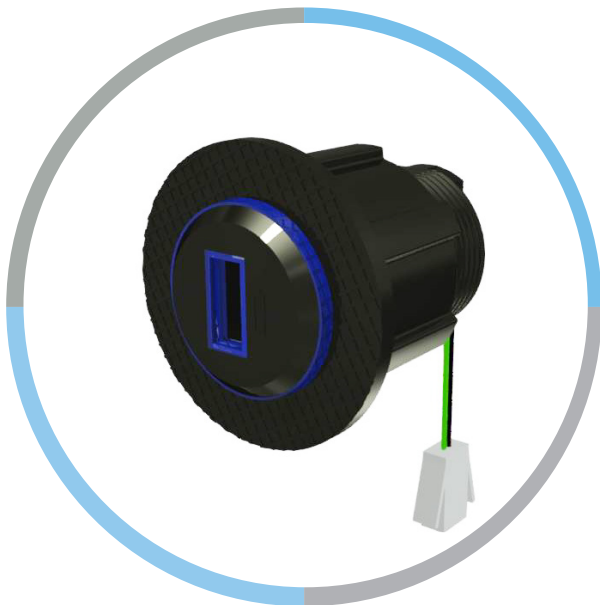

Built-in Kit



Built-up Kit



Speakers

A wide range of speakers with terminals perfect for use anywhere a small footprint speaker is needed.
Available in various sizes and voltages.



PowerPro Power Supplies

200W, 400W and 500W

SUZHAPP has the power supplies you need, now featuring label and connector artwork on our website, to ensure you get the right power supplies every time.



Joysticks

- ✓ Supplied with microswitches with 4.8 mm or 6.3 mm
- ✓ Realistic spring action
- ✓ Available with 4 or 8 ways
- ✓ Ergonomic handle for comfortable grip



Trackballs

- ✓ Exceptional performance
- ✓ Custom colours available
- ✓ No external power supply needed
- ✓ Ease of use



Driving controls

- ✓ Sturdy 2 position shifter
- ✓ Microswitch operation
- ✓ Standard mounting



- ✓ Steering Wheel
- ✓ Ball bearing construction
- ✓ Potentiometer control
- ✓ Standard mounting



LED Light Strips



Controller & wireless remote sold separately

Attract more attention and increase your earnings!

- ✓ Easily installs in or around your machines tension and increase earnings
- ✓ Great for amusement parks and games, casinos, slot machines, arcades, family entertainment centres, theatres, backlighting, decorative lighting, etc.
- ✓ Ideal way to increase earnings on your cranes and pushers
- ✓ Very thin continuous length flexible LED light strips
- ✓ 5m rolls can be separated every 3 LEDs and reconnected again
- ✓ Super bright high-quality SMD LEDs per reel with 120° wide angle illumination
- ✓ 3M adhesive tape on back for easy installation
- ✓ Operates with +12VDC power supply (150-0072)
- ✓ Solid state, high shock or vibration resistant
- ✓ LEDs controlled by controller and wireless remote (sold separately)
- ✓ Each controller can run 65.62 feet (20 meters) of LED strips
- ✓ Long life: 50,000 hours
- ✓ Less power consumption than traditional lights
- ✓ No RF interference
- ✓ Sold in reels of 5m
- ✓ +12VDC; 20W

Adhesive LED Strip Lighting

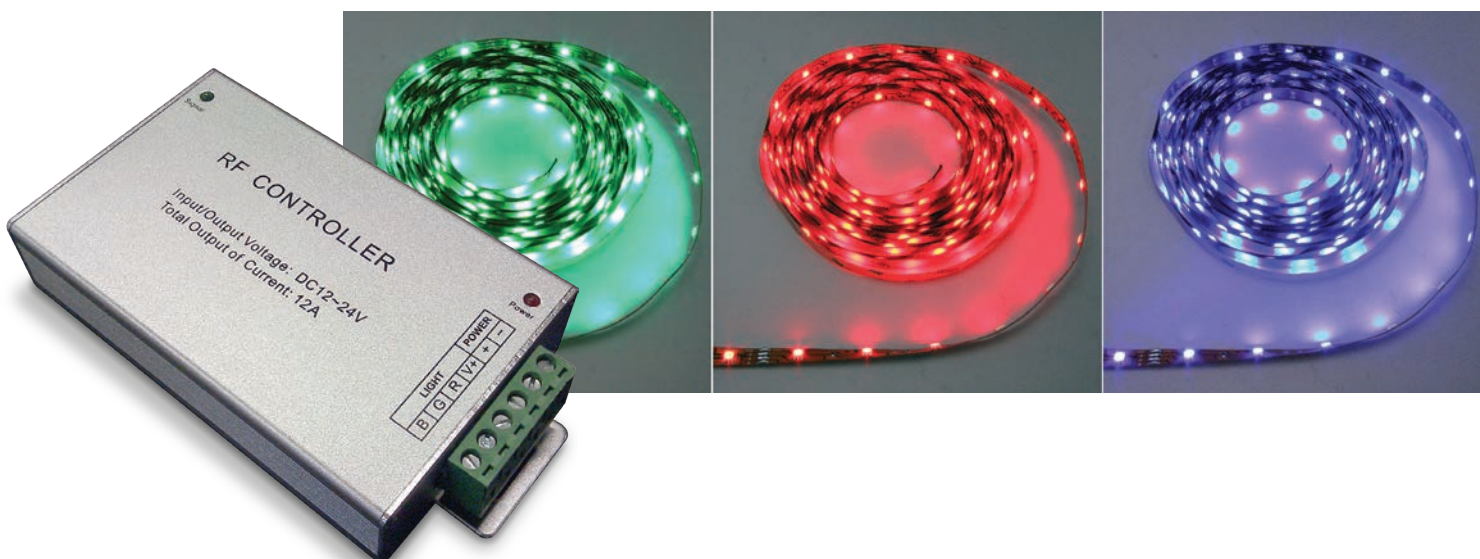

Lamps

Light PRO LED Tubes

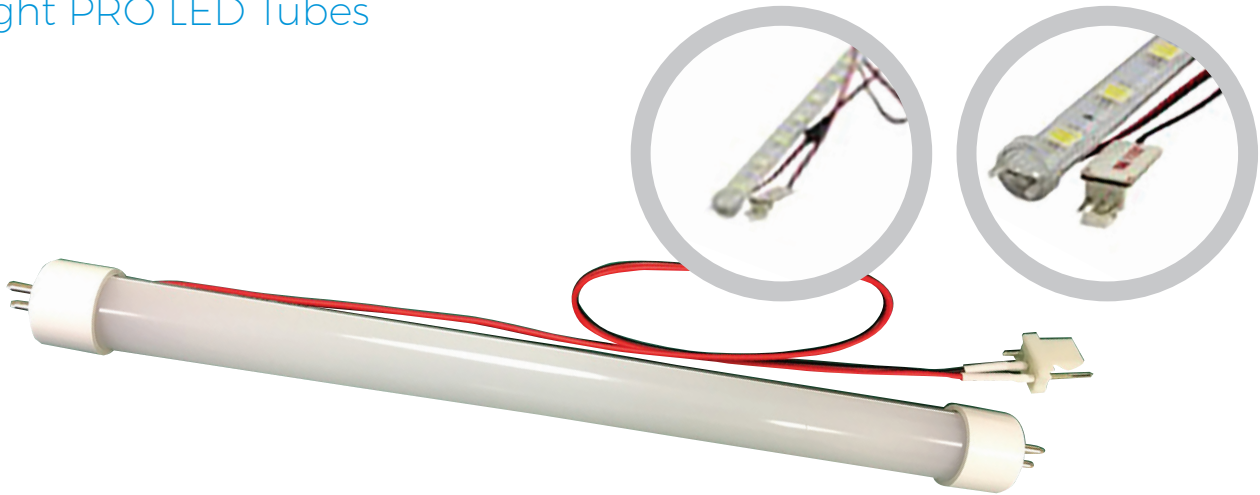

Counters

SEC Starpoint Electronic Counter

Enhanced security is a major feature of the SEC, a unique fingerprint code allows the machine to detect any meter changes and to prevent operation if the meter is not present. By utilizing the latest electronic technology, the SEC avoids the reliability problems and service call-outs which can be experienced with mechanical counting devices.

- ✓ Replaces up to 31 mechanical meters with individual counters stored in EEPROM
- ✓ 7-digit LCD for displaying contents of counters
- ✓ Text messages and counter selection controlled by host machine
- ✓ Clocks serial interface designed to work on existing meter ports
- ✓ Improved security through:
 - Secure software protocol
 - Tamperproof counters with unique fingerprint code



Compact RGB Handle Mechanism



- ✓ Ultra low-profile design allows for external mounting on cabinet and provides increased space inside of the cabinet
- ✓ Easily to remove for improved serviceability
- ✓ Ruggedized die cast design to provide long-term performance
- ✓ RGB attract mode on handle mechanism cover to attract additional attention
- ✓ As handle is pulled LEDs light up with each of the six clicks of the handle movement. All LEDs light up when handle is fully pulled
- ✓ Pre-programmed with unique flashing patterns and colour combinations
- ✓ RGB illuminated mechanism ball with 2 multi-colour LED's that flash, glow or flash light patterns to further trigger your interest in your handle machines
- ✓ 45° rotation

Flip Card Unit



- ✓ Available in two standard sizes for machine flexibility
- ✓ Provides a full deck of cards plus face cards and jokers
- ✓ Driven by standard 12V, 24 step NMB stepper motors
- ✓ Three motor steps per card
- ✓ Designed to include movement detection
- ✓ Separate mounting cradle for ease of machine assembly and service
- ✓ Units can be stacked together or mounted individually
- ✓ Card illumination via RGB LEDs
- ✓ Cards can be driven by the host or through the SUZOHAPP driver board

Custom Reel Mechanisms



Custom Engineered Reel Mechanisms to Fit the Needs of Our Customers



NGT



STARPOINT

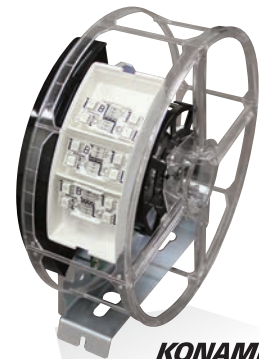

KONAMI.



STARPOINT

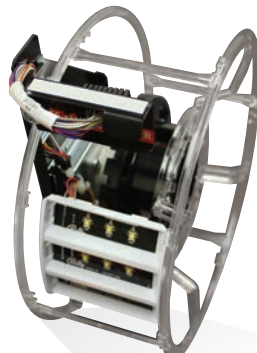

Bally



Bally

E-PRL

Electronic Re-Programmable Lock

Innovative, patented lock using electronics to raise the level of security from mechanical technology. E-PRL is a locking system composed of universal locks with stainless-steel housing and self-powered key sets. It is available in Unique-code or Multi-code versions and includes remote access control management with dedicated GSN-KEY software. No wiring is required for installation and operation.

Features

- Use of steel in all mechanical parts (AISI 316) to stop forced entry and limit wear
- Resistant to water and dust for outdoor applications, IP65 sealing
- No reference on lock for burglary – listing key pair difficult to use in burglary attempts
- Upgrade to E-PRL without modifying existing mechanicals – lengths and diameters of realization stators compatible with existing mechanical version
- No addition or change to wiring on machines with mechanical locks as power is internal to the key
- Modern ergonomic key for comfortable use – dimensions reduced to bare minimum with a harmonic shape
- High-quality Japanese key electronic components
- Inviolable AES 128-bit custom communication system
- Over 10 billion possible key codes due to the electronic system
- Uniqueness of a single key – each key has its own “DNA” derived from on-board electronic data
- Uses a small, easily changeable, long-life Duracell 2430 battery
- Lock stores up to 4,000 accesses between downloads
- High storage capacity of History Key enables storing multiple access locks with a single instrument. The History Key allows downloading and storing up to 32,000 accesses managed through dedicated software

Backward compatibility
The fixing hole, length and rotation of the lock makes it compatible with the most popular machines on the market

Innovation
It's equipped with self-powered advanced electronic technology. No additional wiring is required



Access control
It identifies each user, checks the permissions and records each operation. The event log can be downloaded using a special key

Security
High mechanical strenght, stainless steel housing and electronics with more than 10 billion combinations available, practically endless!

Optional features

Bluetooth Connectivity



Event sharing with other software

ASSA Desmo Locks

Desmo Casino Locks

With many of the world's largest casino groups as a customer the product has become a standard for any casino operator who insist on maximum security combined with maximum operating comfort. The Assa Desmo is a patented lock construction based on direct drive pins (no spring operation) making it particularly suitable for many operations in dirty and hostile environments. False cuts on the pins provide resistance to any currently known method of picking. The Assa Desmo system is the effective way to prevent unauthorized manufacturing, cutting and distribution of key blanks, it also requires the most advanced and precise key cutting equipment in the lock industry.

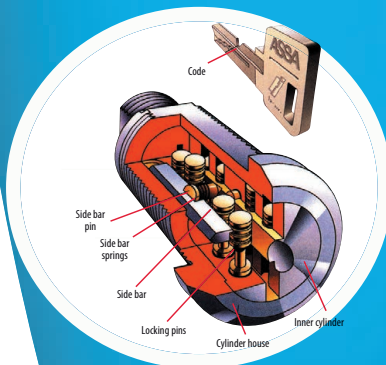
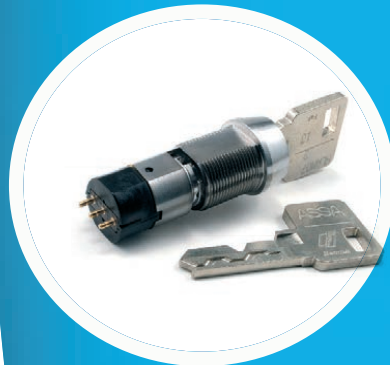
- 8-pin lock combined with two strong side bars
- Large key made of nickel silver for lasting durability and comfortable operation
- Standard 90 degrees operation and key removable in locked position
- Various collars available to adjust any mounting depth
- Standard supplied with 32 mm cam, other sizes and models available
- Key-different locks are supplied with 2 keys per lock



VENIA Locks & Keys

Venia Security Switchlocks DPST



- ✓ 14 pin system, 10 pins on the flat key side and 2 side pins on each side
- ✓ Brass housing with high-quality spindle and bright chrome finish
- ✓ A security collar is included with every Venia lock to prevent any attempts to turn the lock with tools
- ✓ Key made of nickel silver assures longer lifetime and trouble-free operation
- ✓ Only available as key different
- ✓ Connection by 4 solder terminals
- ✓ 2 different switch configurations: pos. 1-3 on/off, pos. 2-4 off/on

Venia Security Camlocks



- ✓ 14 pin system, 10 pins on the flat key side and 2 side pins on each side
- ✓ Brass housing with high-quality spindle and bright chrome finish
- ✓ A security collar is included with every Venia lock to prevent any attempts to turn the lock with tools
- ✓ Key made of nickel silver assures longer lifetime and trouble-free operation
- ✓ Camlocks are available in 3 different lengths: 16 mm (5/8"), 22.3 mm (7/8") and 28.6 mm (1-1/8")
- ✓ Standard 2 position 32 mm cam included

Venia Security Switchlocks



- ✓ 14 pin system, 10 pins on the flat key side and 2 side pins on each side
- ✓ Brass housing with high-quality spindle and bright chrome finish
- ✓ A security collar is included with every Venia lock to prevent any attempts to turn the lock with tools
- ✓ Key made of nickel silver assures longer lifetime and trouble-free operation
- ✓ Venia switchlocks are available with and without automatic key return

Venia Keys



- ✓ Venia keys can only be ordered through SUZOHAPP
- ✓ Key made of nickel silver assures longer lifetime and trouble-free operation
- ✓ These keys can be cut to your specific key code

Xlocks & STC Locks

Security Camlocks Key Alike



Xlock

- ✓ 10 pin operation
- ✓ Die cast housing with chrome finish
- ✓ Camlocks available in 3 lengths: 16 mm (5/8"), 22.3 mm (7/8") and 28.6 mm (1-1/8")
- ✓ Large key provides good grip during operation
- ✓ Key made of nickel silver material for trouble-free performance
- ✓ Standard supplied with 32 mm cam with dual hole so the lock can be mounted in any position

Security Switchlocks



Xlock

- ✓ 10 pin operation
- ✓ Die cast housing with chrome finish
- ✓ Length 36.4 mm (1-7/16")
- ✓ Large key provides good grip during operation
- ✓ Key made of nickel silver material for trouble-free performance
- ✓ Switchlocks have 6.3 x 0.8 mm terminals fitted for easy connection
- ✓ Switchlocks are available with or without automatic key return

STC Round Key Camlocks

High reliable range of camlocks of different sizes to satisfy customer needs.
The locks are available both as key different and key alike.



- ✓ 7-pin tumbler lock
- ✓ Housing with chrome finish
- ✓ Round chrome plated key
- ✓ Available as key different and key alike
- ✓ Available in: 16 mm (5/8"), 22.3 mm (7/8") and 28.6 mm (1-1/8")
- ✓ Cam included

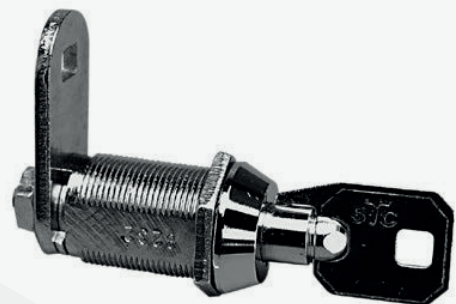

All new key alike series are supplied in lots of 25, 50 or 100 pcs with a total of 5 keys per key code
Re-orders on the same key code are possible with a minimum of 25 locks per key code

© 2018 SUZOHAPP

All rights reserved. Specifications subject to change. 11-06-18

Trademarks owned by their respective holders.

No part of this catalogue may be reproduced in any form by print, photoprint or any other means, without written permission from the publisher.

Technical data, text and pictures are subject to error and modifications.

The catalogue can be subject to further developments.

Simplify your sourcing with our broad product range,
local resources, and global capability

