

Smart Payout

Superior note recycling

An up to 70 note 'true' mixed denomination recycler that can store all denominations from a given currency, eliminating coin starvation & reducing the coin float level required to keep machines operational.

Auto-centering technology straightens notes before reading and all notes in the Smart Payout can be transferred to the cashbox for easy collection.

Features

- Unrivalled mixed denomination note recycler
- Proven field reliability
- Exceptional performance: auto-centering technology straightens notes before reading
- Accepts banknotes up to 85 mm wide & recycles notes up to 82 mm wide
- Easy maintenance, free firmware updates
- Notes in the Smart Payout are transferable to the cashbox

Benefits

- Eliminates coin starvation & the need for multiple hoppers
- Lowest cost of ownership
- Improves operator cashflow
- Reduces operator collection costs
- Future proof - quick & easy updates via USB & PC
- One product suitable for most global applications



Auto-centering technology



Secure cashbox



Technical Schematics

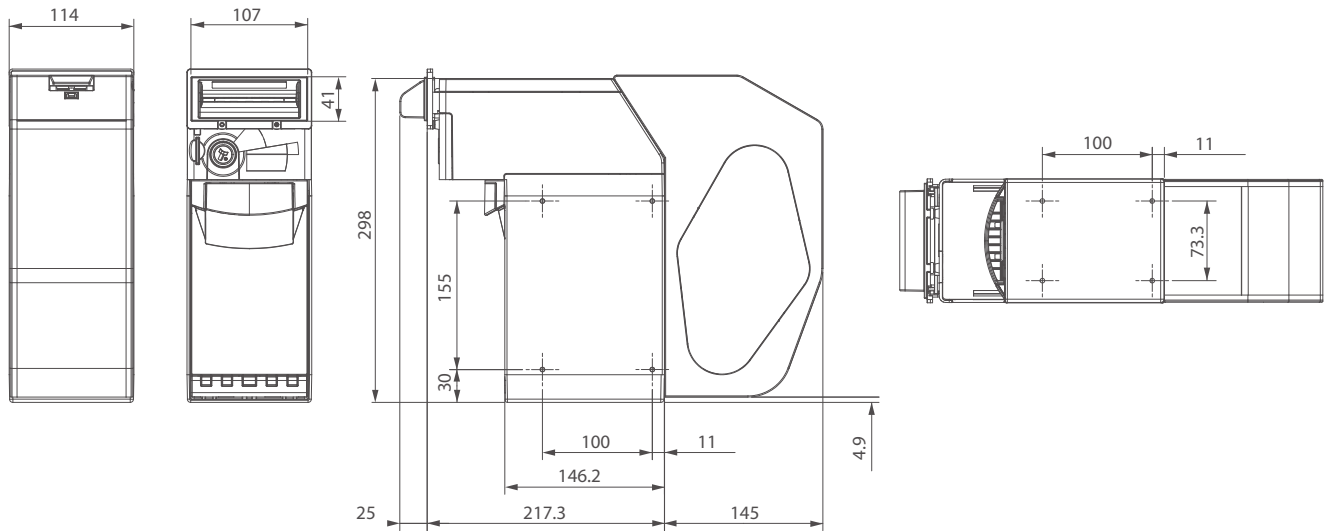

Unit of measure: mm

Functions

A sophisticated winding system makes dispensing fast and secure: Smart Payout can recognise the exact position of the banknote to be dispensed at any given time

Versions

- ccTalk (with IF 14 interface)
- eSSP

Interfaces

- USB with IF 17
- RS232
- Open collector

Optional accessories

- IF 14: interface for converting the eSSP protocol into ccTalk

Bezel options

- 82-85 mm width
- Metal bezel
- Various illumination options

Technical Specifications

Dimensions (LxHxW)	114 x 301 x 387.3 mm
Weight	5.5 kg
Power supply	12 V
Current consumption	400 mA Stand-by – 3 A Running – 5 A Peak
Operating temperature	3 °C ÷ 50 °C - 5 ÷ 95% humidity non-condensed
Banknotes accepted	Width: 60 – 85 mm; Length: 115 – 170 mm
Capacity	Cashbox: 500 or 1,000 banknotes Payout: 70 banknotes
MCBF	100,000